



Cloud Gehshan
Design



UNIVERSITY
of
VIRGINIA

Donor Recognition Guidelines

July 14, 2025

1

Introduction

Introductory Statement

Table of Contents

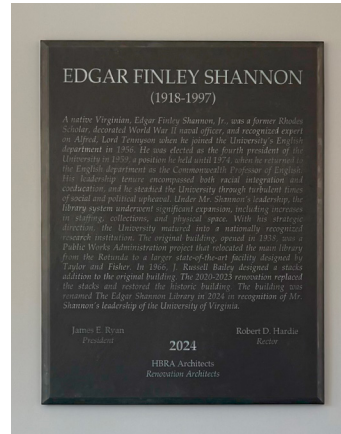

Introductory Statements

Precedent of Donor Acknowledgements

The University of Virginia's reputation as a hub for higher learning and research owes much of its success to the generosity of its donors and the contributions of its community members.

In the past, when a University department or school would acknowledge the efforts of a particular individual(s), they would then design and install a physical piece, like a plaque. The standards, styles, and materials of one department would differ from others as no comprehensive set of acknowledgement standards or guidelines existed.

In consultation with Cloud Gehshan Design, this document guides the standards and styles of acknowledgments on a University-wide basis, in consideration to the core brand and architectural motifs which have been holistically defined in recent years.

Coordination between Development and University Architect

The goal of this document is to encourage conversations between the Office of the Architect and the various offices of development prior to promises made to donors of the acknowledgement's design, fabrication. In this way, consistency across Grounds is ensured and best practices may be known across schools.



Table of Contents

1. Introduction

Introductory Statement
Table of Contents

2. UVA Brand Resources

Glossary Terms
Typography
Color & Paint Specifications
Additional Resources

3. Area Dedications

Dimensional Letters on Existing Site Wall
Monument Signs

4. Building Dedications

Dimensional Letters
Building Dedicatory Plaque
Plaque for Nondedicated Buildings

5. Civic Constructions

Civic Dedicatory Plaque
Masonry Plinth

6. Exterior Spaces & Promenades

Bluestone Pavers
Wall-Mounted Exterior Plaque

7. Exterior Objects

Bluestone Paver Feature
Wall-Mounted Exterior Feature
Freestanding Feature ID

8. Interior Feature Spaces

Dimensional Letters for Dedication
Interior Space ID Plaque

9. Interior Room Recognitions

Room Recognition Plaques
Recognition Plaques with ID
Adapted Use for Interior Features

10. Collective Campaign Guidance

Donor Walls for Renewing Campaigns
Mass Recognition Plaque
Paver Collectives

Table of Contents is Interactive

Click section titles on to go directly to that section's opening page.

At any point, you may return to this page by clicking on the "Donor Recognition" in the upper left of each page.

2

UVA Brand Resources

Acknowledgement Glossary

Typography

Color & Paint Specifications

Additional Resources

Acknowledgement Opportunities

Acknowledgement Opportunity determines the type of physical signage appropriate for the acknowledgement.

Area Dedication: A distinct area Grounds with buildings and landscape features.

Ex: Honorary Grounds, Centers, etc.

Civic Features: Projects that make substantial impact to the UVA environment.

Ex: Bridges, Large Capital Projects, etc.

Building Dedication: A building or facility named after the giving person(s) or party.

Feature Space: A distinct space within interior or exterior areas.

Ex: Plazas, Courtyards, Study Areas, Walkways, Lobbies, etc.

Feature Object: Key items of interest.

Interior Rooms: Spaces tied to building interior.

General Acknowledgement: Recognitions not tied to new construction or project.

Collective Campaigns: Often a drive for mass funding or ongoing contributions, where multiple donors are recognized.

Sponsored Program: Funded research, service, or activity defined by its specific programmatic budget, objectives and/or deliverables.

Acknowledgement Types

Acknowledgement Type determines the layout and context lines which are appropriate to include in physical acknowledgements.

Recognition: The acknowledgement of the donor within the context of their gift.

"A gift by Donor Name"

Dedication: The incorporation of the donor name into the official identification of the relating space, program, or feature.

"The Donor Name Classroom"

Tributary: A recognition or dedication gift given by one party in honor of a person or special event. Often contains both the tribute and the donor.

"In honor of Tributary Person, with thanks to Donor Person"

Memorial: A recognition or dedication to a person who has passed away, given in their memory.

"In memory of Dear Person"

Honorific: A dedication to a member of UVA's community, bestowed upon by the University's President and Rector.

"The University recognizes Honored Person"

Approved Typography

Adobe Caslon Pro

University of Virginia's primary typeface. Used in acknowledgments for open areas of Grounds, as well in designs for buildings of classical style.

ABCDEFGHIJKLMN**OP**QRSTUVWXYZ
abcdefghijklmnopq**rstu**vwxyz
1234567890 &!?,.”

Semibold

ABCDEFGHIJKLMN**OP**QRSTUVWXYZ
abcdefghijklmnopq**rstu**vwxyz
1234567890 &!?,.”

Regular

*ABCDEFGHIJKLMN**OP**QRSTUVWXYZ
abcdefghijklmnopq**rstu**vwxyz
1234567890 &!?,.”*

Regular Italic

Franklin Gothic

The typeface for acknowledgments in and on buildings of contemporary style.

ABCDEFGHIJKLMN**OP**QRSTUVWXYZ
abcdefghijklmnopq**rstu**vwxyz
1234567890 &!?,.”

Medium

ABCDEFGHIJKLMN**OP**QRSTUVWXYZ
abcdefghijklmnopq**rstu**vwxyz
1234567890 &!?,.”

Book

Cavalier

The typeface for acknowledgments in and on buildings of Cavalier athletic use.

**ABCDEFGHIJKLM
NOPQRSTUVWXYZ
1234567890**

Bold

Color and Paint Specifications



UVA Blue

Pantone: 2767C

MP112754, UVA Blue, Satin Finish



UVA Orange

Pantone: 185C

Matthews Paint MP112755, UVA Orange, Satin Finish



Cavalier Orange

Pantone: 172 C

Matthews Paint to match



Designer White

Pantone: Brilliant White, 11-4001 TPG

Matthews Paint: Designer White, Satin Finish



Black

Pantone: Black C

Matthews Paint: PROC BLACK C, Satin Finish

Matthews Paint Company

800.323.6593

www.matthewspaint.com

Matthews paint products are specified for exterior signage and display hardware and related elements.

Gloss finish of paint specified is to be 60 degrees or 29.8 on a 60 degree glossimeter. Refer to performance requirements of exact specifications.

All acrylic polyurethane finishes require final clear coat finish.

Exterior: apply Matthews 290228SP Super Satin Clear Coat

Interior: apply Matthews Matthews Acrylic Polyurethane (MAP®) SOA 4158SP ADA Clear Coat

Additional Resources

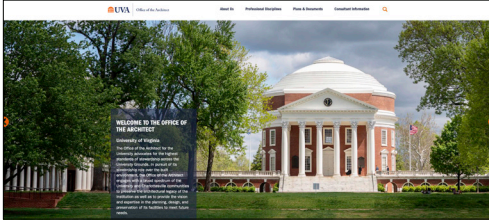

UVA's Office of the Architect Webpage

Coordination with the OAU is essential prior to putting any acknowledgement within the physical landscape.

[Visit Page](#)

UVA Office of the Architect
 445 Rugby Road (O'Neil Hall)
 P.O. Box 400304
 Charlottesville, VA 22904-4304

Phone: (434) 924-6015
 FAX: (434) 924-6014
 uarch@virginia.edu



BrandDot Virginia

For questions regarding the UVA Brand, and for resources including Art, Colors, Fonts, Logos templates, etc.

[Visit Page](#)

University Communications
 2420 Old Ivy Road
 P.O. Box 400229
 Charlottesville, VA 22904-4229

(434) 924-1400
 brand@virginia.edu



Wayfinding Signage Standards

Published in 2024 in consultation with Cloud Gehshan Design, these standards regard wayfinding signage on Grounds.

[View Document](#)

3

Area Dedications

4" to 7" Dimensional Letters on Existing Site Wall
Monument Sign

Sign Type Applications

Area Dedications

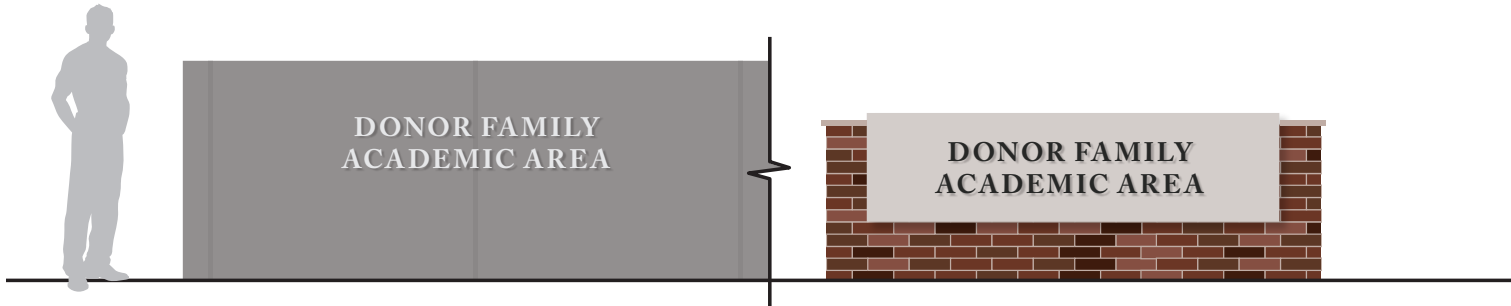

Dimensional Letters on Existing Site Wall

5" to 7" letter height

Requires solid-color background,
back panel to be added otherwise.

Monument Sign

Brick Option Shown – Wall material
to be selected in consideration with
the landscape architecture of the area.

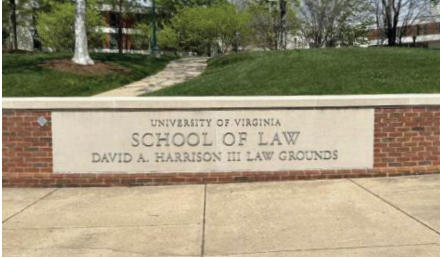

Best Practices & 2025 Precedent

Monument Sign / Site Wall for Area Dedication

This is the largest and most significant dedication opportunity at UVA. Only major exterior Area Dedications should receive a Monument Sign / Site Wall treatment. Criteria for OAU Approval is as follows:

- 1. Coordination** Present content, site conditions, and proposal to OAU.
- 2. Nomenclature Content** The Monument Sign should be as concise as possible, recognizing a University function alongside its dedicated donor name. This is the only information which should appear on the sign.
- 3. Dimensional Letters** Only use Caslon font, set in Uppercase, 4" to 7" in height, 1/2" to 1" in depth, and spaced off of their wall. Color or material should achieve 70% contrast against their backer.
- 4. Design of Wall** Materiality is to match that of its surrounding environment. For non-continuous materials like brick or fieldstone, a backer of continuous material must be used for letter contrast.
- 5. Placement** This sign type acts as a pedestrian, not vehicular, gateway to Grounds. Can either be placed on an existing retaining or freestanding wall, or a new wall may be created during the development construction process. Ensure landscaping will not grow to obscure sign content.



Example Precedent and Observations

The Breeden Commerce Grounds exemplifies how the monument sign interacts at the pedestrian-level, matches the materials of the surrounding environment, and is equipped with appropriate nomenclature, font use, and letter size.

Content Nomenclature

Area Dedications | Monument Sign / Letters on Site Wall

**DONOR FAMILY
ACADEMIC AREA**

Nomenclature Identifies Name and Function

The Area Dedication's Monument Sign / Site Wall should recognize a University function alongside its dedicated donor name.

This is the only information that is to appear on this sign.

DONOR FAMILY AREA

Not to be Approved

Avoid creating a Monument Sign / Site Wall with no clear ties to a University function, service, or activity.

UNIVERSITY OF VIRGINIA · CENTRAL GROUNDS

**DONOR FAMILY
ACADEMIC AREA**

SCHOOL OF ACADEMIC STUDIES

Do not add additional information to the Monument Sign / Site Wall. The Monument Sign / Site Wall's nomenclature, design, and placement will relate it to UVA without the need for additional information.

Content Limitations

Area Dedications | Monument Sign / Letters on Site Wall

DONOR FAMILY ACADEMIC AREA

Concise Party Recognition

There are no character limitations of names for Area Dedications, however they should appear in a similar manner as to how they will be spoken aloud. Entire legal names are not necessary for donor identification, nor appropriate for this recognition.

~~THE JOHN DANIEL DONOR JR. '76
AND GRETA GENEROUS DONOR '78
FAMILY ACADEMIC AREA~~

~~IN HONOR OF BELLA DONOR '22~~

Not to be Approved

Dedications come from one joined party or family name. There are no distinctions for honorifics or memorials.

Refrain from using middle names, middle initials, grad year or attended schools.

All content to be approved by the OAU early within the process to assist in designing the dedication accordingly.

Typography and Typestyle

Area Dedications | Monument Sign / Letters on Site Wall

**DONOR FAMILY
ACADEMIC AREA**

Font is Adobe Caslon Pro, Semibold

Letters are to be set in all-Uppercase format.

This type treatment is appropriate for non-athletic areas of Grounds.

~~**DONOR FAMILY
Academic Area**~~

~~**DONOR FAMILY
ACADEMIC AREA**~~

~~**DONOR FAMILY
ATHLETIC AREA**~~

Not to be Approved

Do not use typestyles other than all-Uppercase.

Fonts other than Adobe Caslon Pro Semibold will not be approved.

Unlike the Typical / Contemporary / Athletic styles existing on the facade and interior of buildings, no such distinction is made for general exterior areas of Grounds, and therefore Franklin Gothic and Cavalier should not be used for Monument Signs / Site Wall Treatments.

Letter Height Size

Area Dedications | Monument Sign / Letters on Site Wall



4" to 7"
**DONOR FAMILY
ACADEMIC AREA**

Letter Height is a Range

Dimensional letters are to be within 4" to 7" in height.

The range is provided to accommodate donor name size, prominence of recognition in its environment, available wall space, and reading distance.



letters larger than 7"
**DONOR FAMILY
ACADEMIC AREA**



letters smaller than 4"
**DONOR FAMILY
ACADEMIC AREA**

Not to be Approved

Sizes of letters outside of the given range, or at a size not legible or appropriate for their reading distance will not be approved.

Letter Depth and Mounting

Area Dedications | Monument Sign / Letters on Site Wall

Spacers are 1/8" to 1/4"

Letters are 1/2" to 1"

Pins are sealed into wall

Letter Depth

Dimensional letters are 1/4" to 1" in depth. The preferred face of the letters is flat. One method to decide thickness is to consider 1:8 ratio of width to height.

Letter Mounting

1/8" to 1/4" spacers which separate the letters from their surface is preferred to reduce debris build-up.

Ensure that the pins and letters are secure by increasing contact points and using a sealant.

Hardware of mounting mechanism to be the same metal as letters to prevent galvanic corrosion. Should multiple metals be detailed, in this regard, they must include a neoprene gasket between them for separation.

Side view of pin-mounted letters

Letters protrude over 3/4"

no spacers

Side view of oversized flush letters

Spacers protrude over 1/4"

Few contact points

No sealant used on pins

Side view of improper pin-mounted letters

Not to be Approved

Dimensional letters should protrude no more than 3/4"

Fewer pins creates weak contact points and risks a higher chance of letters breaking from their support.

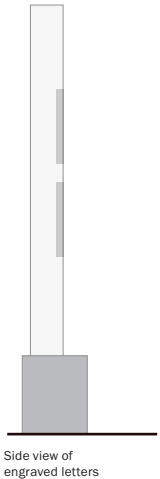

Consult with OAU

Engraved letters are not favored due to their inability to be maintained piece-by-piece. Consult with the Office of the Architect for these options.

Dimensional Letter Material Notes

Area Dedications | Monument Sign / Letters on Site Wall

Natural / Painted Aluminum

An affordable, readily available option which can provide a high-end polished appearance.

Bare aluminum gives a light silvery gray color, better against darker backgrounds.

Recommended surface treatment is horizontally-brushed with short-grade strokes.

Paint may be matte, satin, or gloss depending on surrounding architectural palette or conditions. Glossier finishes are generally more protective of environmental elements, but harder to touch up. Clear coat is required.

Powder coat options, at a higher cost, offer additional durability.

Anodized Aluminum

This process coats the aluminum letters in a protective material, giving the letters color and preserving their metallic grain finish.

Very durable, but with a hard enough of a strike, the color can scratch away similar to paint. Unlike paint, however, anodized materials are harder to touch up.

Colors may vary from batch-to-batch, making management for multiple orders difficult.

Custom colors are often an additional expense.

Clear coat required.

Stainless Steel

A durable and bold material, the 316 alloy is optimal to prevent corrosion, patinas, rusts, and color bleeds which occur in other alloys of stainless steel.

Naturally darker in appearance than bare aluminum, giving letters more contrast against lighter materials.

Clear coat required.

Blackened Steel

A process which pre-oxidizes the steel, giving letters greater durability and an even darker appearance. This option may be considered for an architectural approach of dark letters that is paint-free approach.

Alternative Material Considerations

There is a level of adaptability for dimensional letters to match their architectural environment.

Durable exterior materials, ex. corian, may be desired for an adaptability to the architecture of the building. Proposals must be assessed by the Office of the Architect. Consider cost, maintenance, and accordance with surrounding environmental conditions and architecture.

Proposed material samples should be procured and examined in their desired landscape.

Expectation of Quality

Materials and finishes should have a 10-year warranty. Automotive paints & products are often exceptionally durable.

Contrast of Paint or Material

Area Dedications | Monument Sign / Letters on Site Wall



DONOR FAMILY
ACADEMIC AREA



DONOR FAMILY
ACADEMIC AREA



DONOR FAMILY
ACADEMIC AREA



DONOR FAMILY
ACADEMIC AREA

70% Contrast

Contrast should be considered when deciding upon the letter colors or legibility purposes, letters are to be set in all-Uppercase format.

Backer for Noncontinuous Surfaces

Any letters set onto a noncontinuous surface, like fieldstone or brick, require a inset, panel, or wall saddle for their letters to achieve contrast.

Not to be Approved

Letters which are low visibility by material, color, or finish are not acceptable for this recognition type.

Letters placed directly onto a noncontinuous surface do not offer adequate legibility, a backer must be used in these instances.

Wall Materiality & Design Standards

Area Dedications | Monument Sign / Letters on Site Wall

Designs for New Construction

These designs incorporate niches into the architecture building of the wall itself.



Dimensional Letters on Inset in Brick Wall



Dimensional Letters on Inset in Stone Wall

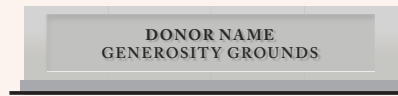

Dimensional Letters on Inset in Concrete Wall

Designs for New Construction or Retrofitting Existing Walls

These designs have panels and letters installed on top of the existing wall.



Dimensional Letters on Panel on Brick Wall



Dimensional Letters on Panel on Stone Wall

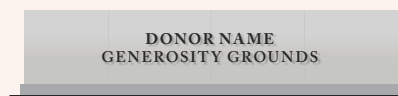

Dimensional Letters on Concrete Wall

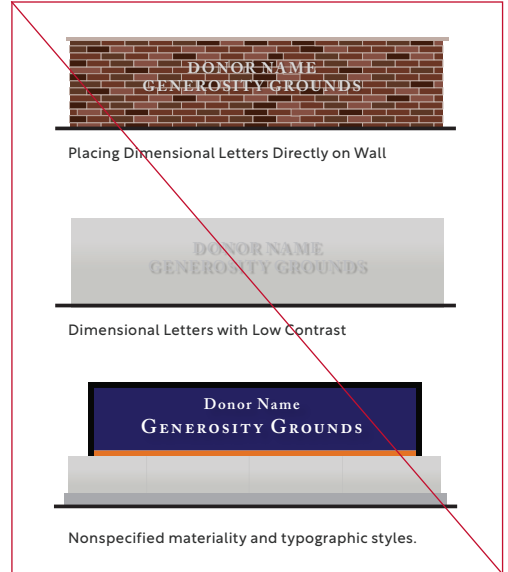

Not to be Approved

Deviations from typographic and material standards are not acceptable.

Masonry Panel on Capped Wall

Area Dedications | Monument Sign / Letters on Site Wall



Perspective view of panel sign underneath existing wall with cap

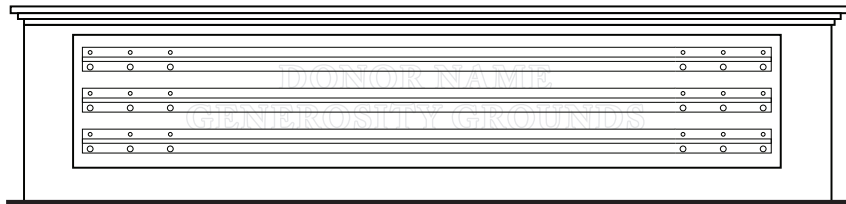

Section view of continuous Z clip rails which would receive the masonry panel

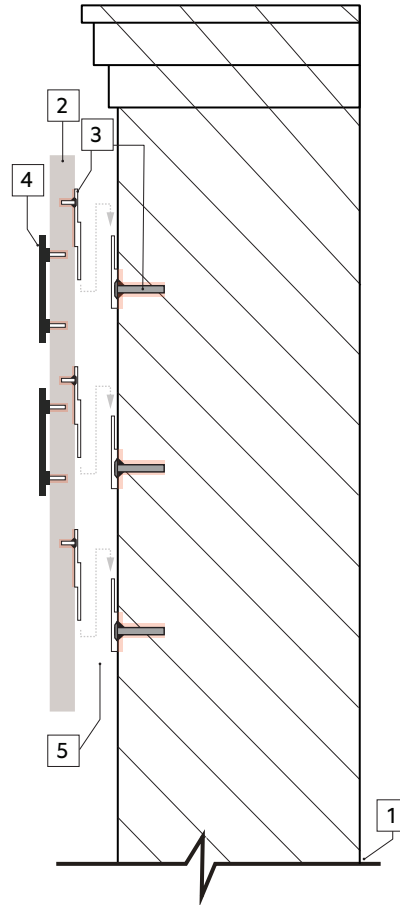

- 1 Provide foundation details with engineer seal
Sign fabricator to verify all existing site conditions and inform client and designer of any issues that will affect design intent
- 2 Masonry panel of continuous material, no thicker than 2", decided by OAU to match surrounding architectural / environmental palette
- 3 Masonry anchors suggested by fabricator, file welded onto 3 rows of continuous length Z clips, sealed into their material using an epoxy or other exterior-grade adhesive. Z clips can be further secured by using an epoxy or other exterior-grade adhesive on the flat faces which meet their panel
- 4 Pins are welded or adhered onto dimensional letters, inserted into pre-drilled panel and sealed into place using an epoxy or adhesive graded for exterior use. 1/4" to 1/2" thick aluminum spacers are used to separate the letters from the wall
- 5 Mortar around the open separation between the panel and the wall after installation

Seek Expertise & Approval

Drawing shows design intent and general architectural standard. As-built conditions will vary.

Always consult the OAU, Facilities Management, signage fabricators, and masonry experts prior to placing signage into the landscape.

Masonry Saddle on Noncapped Wall

Area Dedications | Monument Sign / Letters on Site Wall



Perspective view of masonry saddle over existing wall

Considerations for Metal

A continuous masonry material is the typical standard for the backer which letters are mounted onto, although metals in a brake-formed L Shape can be considered with the OAU.

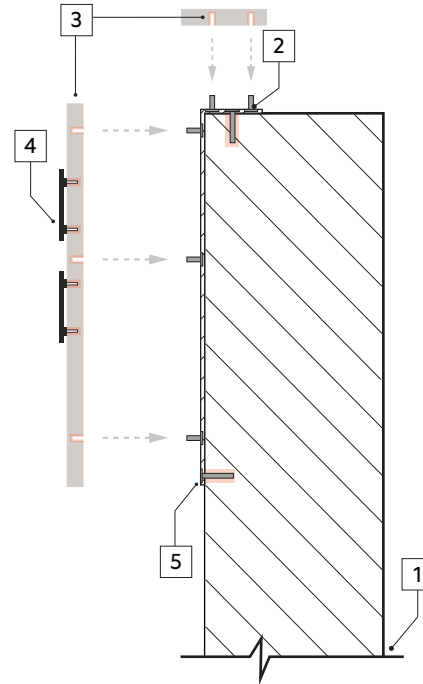

- 1 Provide foundation details with engineer seal
Sign fabricator to verify all existing site conditions and inform client and designer of any issues that will affect design intent
- 2 1/4" thick aluminum panel, break-formed at 90°. Masonry anchors suggested by fabricator, file welded onto aluminum panel and sealed into wall and masonry panel using an epoxy or other exterior-grade adhesive
- 3 Masonry panel of continuous material, no thicker than 2", decided by OAU to match surrounding architectural / environmental palette. Pre-drilled holes are made into the panel to receive masonry anchors
- 4 Pins are welded or adhered onto dimensional letters, inserted into pre-drilled panel and sealed into place using an epoxy or adhesive graded for exterior use. 1/4" to 1/2" thick aluminum spacers are used to separate the letters from the wall
- 5 Mortar around the open separation between the panel and the wall after installation

Seek Expertise & Approval

Drawing shows design intent and general architectural standard. As-built conditions will vary.

Always consult the OAU, Facilities Management, signage fabricators, and masonry experts prior to placing signage into the landscape.

Consideration for Wall Height

Area Dedications | Monument Sign / Letters on Site Wall



Consideration of Use

Height and design for the Monument Sign is to be set on a case-by-case basis. If placed in a common courtyard area, the sign may be used as seating by those within the space.

Donors who make the large gift for Area Dedications may find this either acceptable or objectionable.



Recommended Adjustment

If sitting on top of the sign is objectionable, consider a design where the panel is elevated of the wall, and encourage seating elsewhere with available lower walls.

Placement & Landscaping

Area Dedications | Monument Sign / Letters on Site Wall

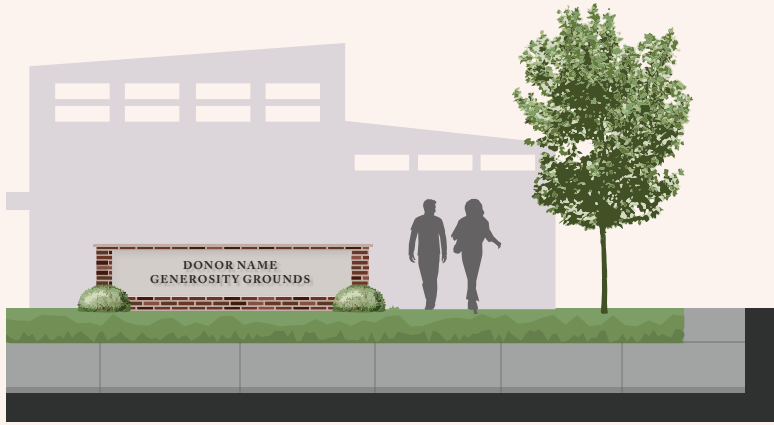

Pedestrian Gateway into Dedicated Area

The Monument / Site Wall should exist within its pedestrian area, in close proximity to buildings and landscape features. Site walls alongside pedestrian pathway entrance points are opportune points to incorporate dimensional letters which identify the Area Dedication.

Maintained Landscaping Permitted

Foliage can help incorporate the signage into the landscape, but ensure overgrowth will not cover sign material.

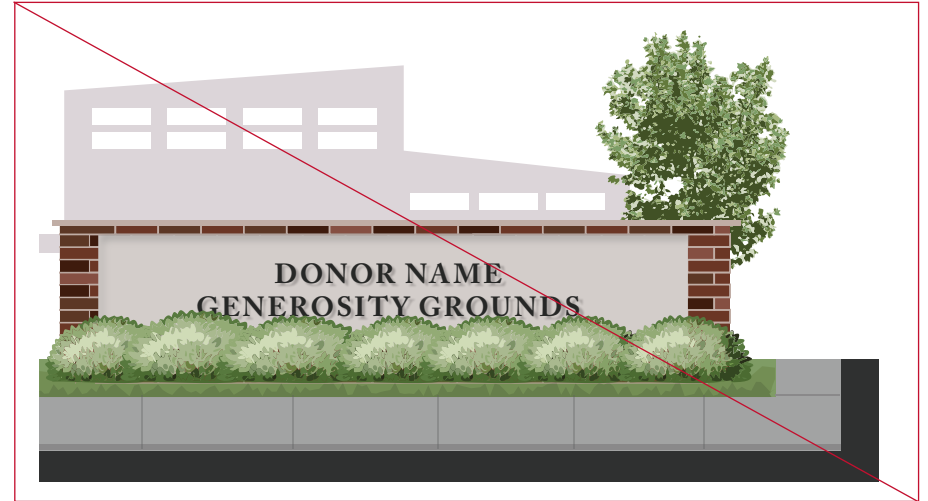

Not to be Approved

Avoid placing the sign at busy, public vehicular intersections. The sign should act as a pedestrian gateway rather than a vehicular one.

Signs should not be placed where they obscure landscape features from view. Foliage in front of the sign should not obscure sign content.

4

Building Dedications

3" to 9" Dimensional Letters

Building Dedication Plaque

Plaque for Nondedicated Buildings

Sign Type Applications

Building Dedications

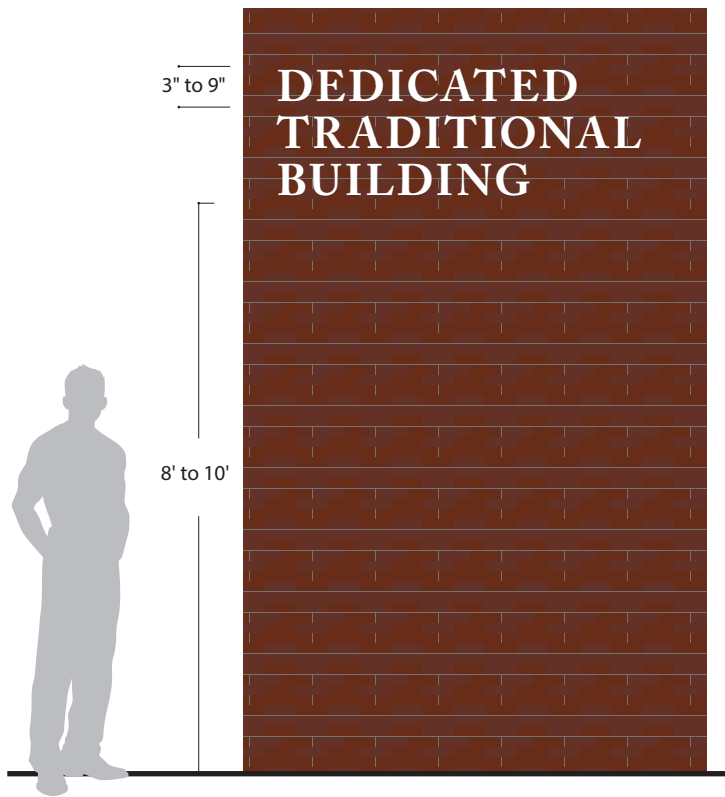

DEDICATED
TRADITIONAL
BUILDING

Dimensional Letters
for Building Identification
Typical / Classical Palette

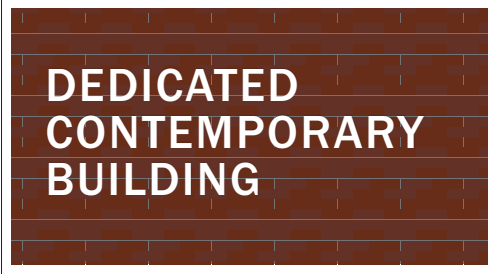

DEDICATED
CONTEMPORARY
BUILDING

Contemporary Palette



DEDICATED
ATHLETICS
BUILDING

Athletics Landscape

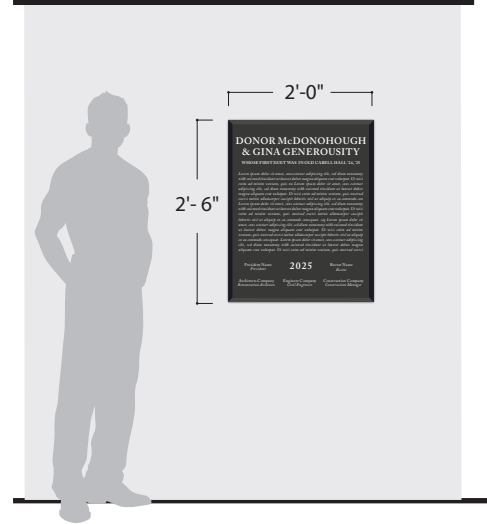

DONOR McDONOUGH
& GINA GENEROSITY

2025

Building Dedication Plaque
Only for use of dedicated buildings.



Example Precedent and Observations

The nomenclature, Caslon font, and above-entry placement of the dimensional letters which identify the Shannon Library are of good precedent for a building of classical architecture.

The full donor name within the Molly and Robert Hardie Football Operations Center could have been off-loaded to the Building Dedication Plaque. "Hunter Smith" may be appropriate in full as a wayfinding distinction from the C. Ray Smith Alumni Hall and Carl Smith Center.

Best Practices & 2025 Precedent

Dimensional Letters for Building Dedication

The primary and preferred method of identifying a building directly onto its architecture. (Note that the rules for dimensional letters laid out in this section apply for both dedicated and nondedicated buildings).

1. Coordination Present content, site conditions, and proposal to OAU.

2. Nomenclature Content Concise donor name and minimal functional name. Family names are unified when applicable.

3. Typography Style and use of building determines use of Caslon, Franklin, or Cavalier fonts. Letters are to be set in all Uppercase.

4. Design 3" to 9" in height, 1/2" to 1 1/8" in depth, and in a color / material achieving 70% contrast against the wall they are placed on.

5. Placement and Orientation Optimally, 8' to 10' high on a face of the building which. Letters are right aligned if placed on a wall field, or center-aligned if over doorway.

Nomenclature & Content Limitations

Building Dedications | Dimensional Letters

McDONORHUGH
FINE ART STUDIOS

Concise Donor Name and Functional Use

Building dedications should be concise as possible. An indication of academic function or use is to be included as well.

All family names should be joined in one instance, hyphens may be used if dedication comes from two parties.

~~THE STEFANIE BELFORD '89 &
SAMSON G. '91 McDONORHUGH
FAMILY FINE ART STUDIOS
IN HONOR OF SAMMY S. McDONORHUGH~~

Not to be Approved

Dedications come from one joined party or family name. There are no distinctions for honorifics or memorials.

Refrain from using middle names, middle initials, grad year or attended schools. Use ampersands when applicable

All content to be approved by the OAU early within the process to assist in designing the dedication accordingly.

Typesyles & Fonts

Building Dedications | Dimensional Letters

SMITH BIOLOGY BUILDING

MYERS RESEARCH HALL

DOE VOLLEYBALL FACILITY

Letters are to be set in all-Uppercase format.

Traditional Architecture: Adobe Caslon Pro, Semibold

Appropriate for buildings deemed by the OAU to be of the traditional style of Grounds.

Contemporary Architecture: Franklin Gothic URW, Medium

Appropriate for buildings deemed by the OAU to be of the contemporary architectural style of Grounds.

Athletic Use: UVA Cavalier Font, Bold

Appropriate for buildings deemed by the OAU and Athletics Department to be of athletic use on Grounds.

~~SMITH BIOLOGY BUILDING~~

~~Smith Biology Building~~

~~SMITH BIOLOGY BUILDING~~

~~Smith Biology Building~~

Not to be Approved

Typefaces, fonts, and typesyles outside of these standards will not be approved. Incorrect uses of approved fonts is not acceptable.

Lowercase and Small-Caps typesyles are not to be used.

Letter Height

Building Dedications | Dimensional Letters



Provided Range for Architectural Consideration

Dimensional letters are to be 3" to 9" in height.

The range is provided to accommodate donor name size, prominence of recognition in its environment, available wall space, and reading distance.



Not to be Approved

Sizes of letters outside of the given range, or at a size not legible or appropriate for their reading distance should be reconsidered appropriately.

Letter Depth & Mounting

Building Dedications | Dimensional Letters

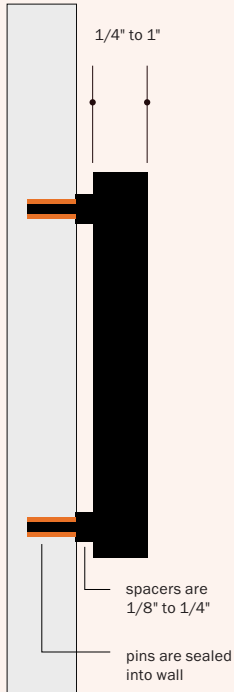

Side View, secure pin-mounted

Letter Depth

Dimensional letters are 1/4" to 1 1/8" in depth. The preferred face of the letters is flat. One method to decide thickness is to consider 1:8 ratio of width to height.

Letter Mounting

1/8" to 1/4" spacers which separate the letters from their surface is preferred to reduce debris build-up.

Ensure that the pins and letters are secure by increasing contact points and using a sealant.

Hardware of mounting mechanism to be the same metal as letters to prevent galvanic corrosion. Should multiple metals be detailed in this regard, they must include a neoprene gasket between them for separation.

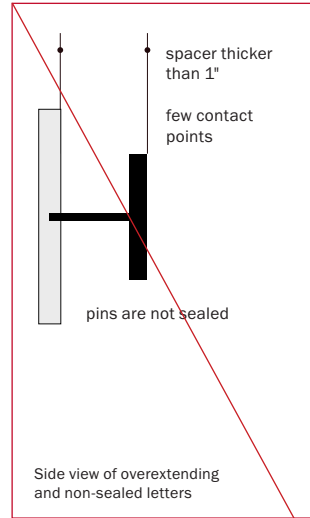

Side view of overextending and non-sealed letters

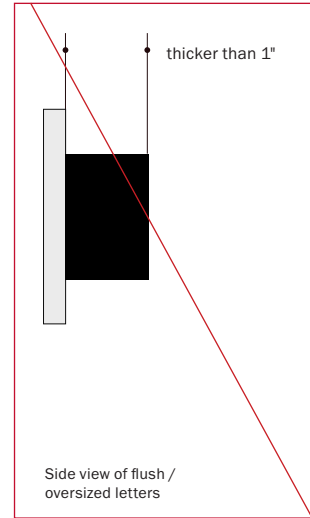

Side view of flush / oversized letters



Side view of engraved letters

Not to be Approved

Dimensional letters should protrude no more than 1". Few pins creates weak contact points and risks a higher chance of letters breaking from their support.

Consult with OAU

Engraved letters are not favored due to their inability to be maintained piece-by-piece. Consult with the Office of the Architect for these options.

Materiality & Contrast

Building Dedications | Dimensional Letters

SMITH BIOLOGY BUILDING

SMITH BIOLOGY BUILDING

70% Contrast, Consult with OAU with Color

Material and paint colors will be determined by the OAU to meet an adequate contrast against the wall it is placed on, and to match the surrounding architectural palette.

Materiality Responds to Architecture

Letters should be whatever material, paint, or finish which matches the surrounding architectural palette.

SMITH RESEARCH FACILITY

Consult with OAU

The use of high-polish or mirror-finished letters should be given additional consideration to ensure their legibility.

SMITH BIOLOGY BUILDING

SMITH BIOLOGY BUILDING

Not to be Approved

Letters that do not reach a legible contrast with their background wall should be reconsidered

Avoid using colorful materials or paints which do not correlate to the building's architectural palette.

Dimensional Letter Material Notes

Building Dedications | Dimensional Letters

Natural / Painted Aluminum

An affordable, readily available option which can provide a high-end polished appearance.

Bare aluminum gives a light silvery gray color, better against darker backgrounds.

Recommended surface treatment is horizontally-brushed with short-grade strokes.

Paint may be matte, satin, or gloss depending on surrounding architectural palette or conditions. Glossier finishes are generally more protective of environmental elements, but harder to touch up. Clear coat is required.

Powder coat options, at a higher cost, offer additional durability.

Anodized Aluminum

This process coats the aluminum letters in a protective material, giving color to the letters color and preserving their metallic grain finish.

Very durable, but with a hard enough of a strike, the color can scratch away similar to paint. Unlike paint, however, anodized materials are harder to touch up.

Colors may vary from batch-to-batch, making management for multiple orders difficult.

Custom colors are often an additional expense.

Clear coat required.

Stainless Steel

A durable and bold material, the 316 alloy is optimal to prevent corrosion, patinas, rusts, and color bleeds which occur in other alloys of stainless steel.

Darker in appearance than bare aluminum.

Clear coat required.

Material Not Listed

There is a level of adaptability for dimensional letters to match their architectural environment.

Durable exterior materials, ex. corian, may be desired for an adaptability to the architecture of the building. Proposals must be assessed by the Office of the Architect. Consider cost, maintenance, and accordance with surrounding environmental conditions and architecture.

Proposed material samples should be procured and examined in their desired landscape.

Expectation of Quality

Materials and finishes should have a 10-year warranty. Automotive paints & products are often exceptionally durable.

Dimensional Letters on Noncontinuous Surfaces

Building Dedication | Dimensional Letters



Consideration of Legibility

Noncontinuous materials, like stone walls and sometimes brick, make for a difficult surface for letters to achieve legibility upon.



Consult with OAU

The incorporation of a continuous material backer – like aluminum or masonry material – may be incorporated to assist contrast.

Placement and Orientation

Building Dedication | Dimensional Letters

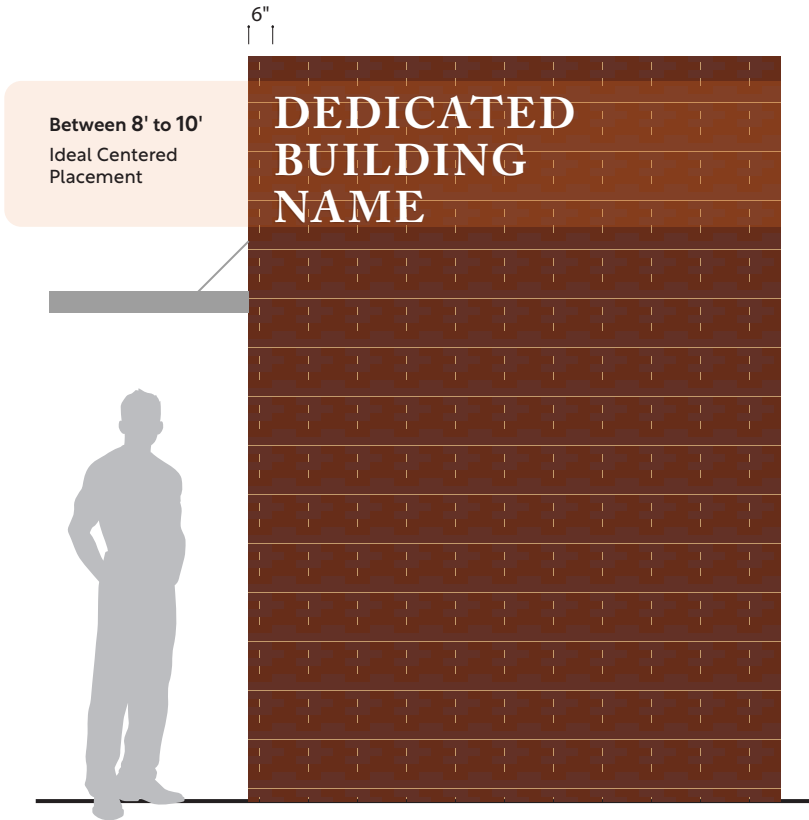

Placement Range for Architectural Consideration
 Optimal height is between 8' and 10' high.
 The placement of letters should indicate the leading of an entrance.

Acceptable Orientations
 Letters placed on a corner wall should be left-aligned.
 If above a doorway or portal, letters may be center-aligned.

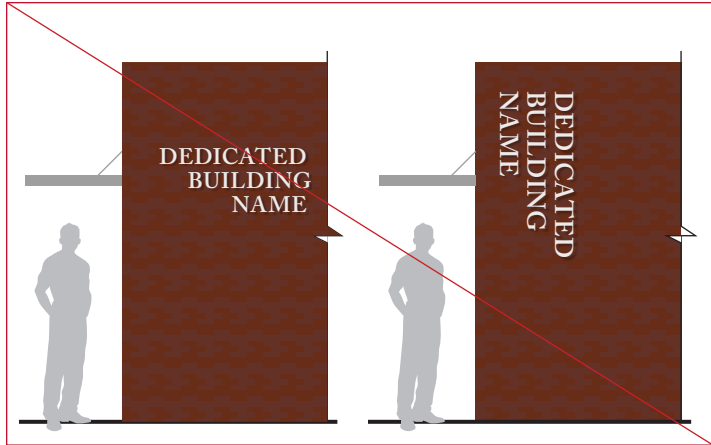

Not to be Approved

Do not place letters at heights and alignments which do not correlate with an entryway.

Alignments that deviate from standards are unacceptable.

Lower Placement

Building Dedication | Dimensional Letters

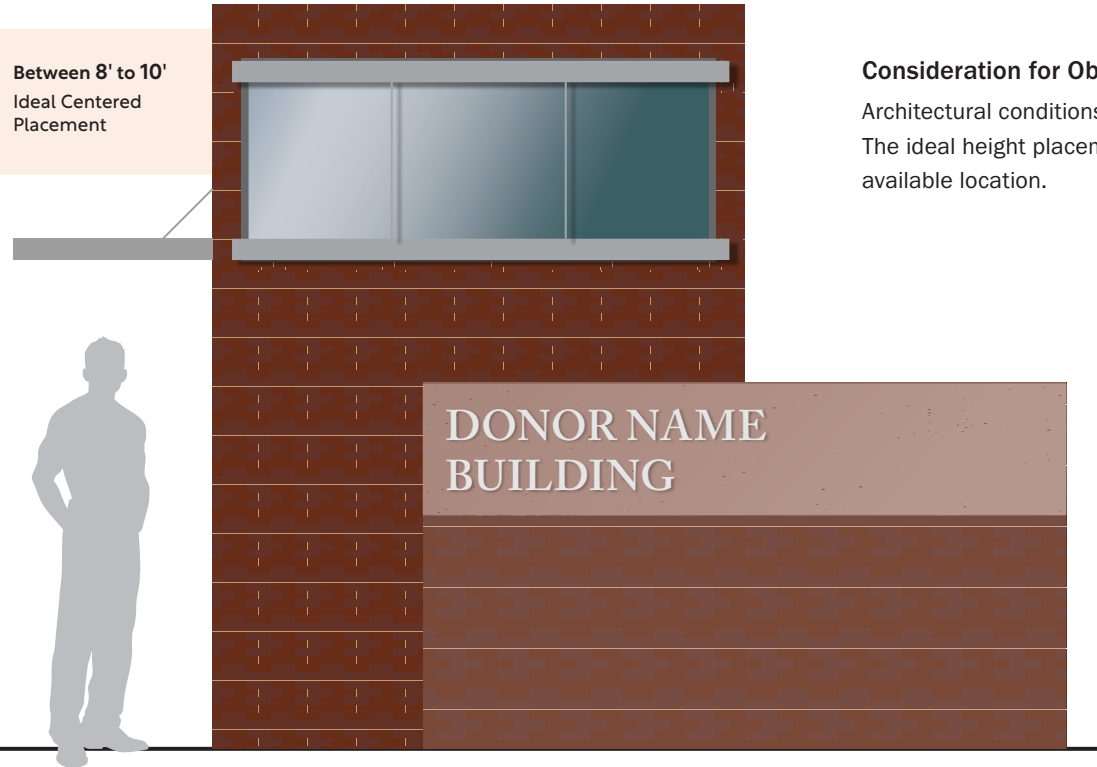

Consideration for Obscured Placement

Architectural conditions vary building-from-building. The ideal height placement is not always an available location.

Seek OAU Approval

Dimensional Letters may be placed on nearby wall which is clearly connected to the building it references.

As this placement is closer to eye level, the lower range of letter height size should be used.

As the letters are within grabbing range, greater means of tamper-proofing for installation should be preferred.

Canopy Placement

Building Dedication | Dimensional Letters

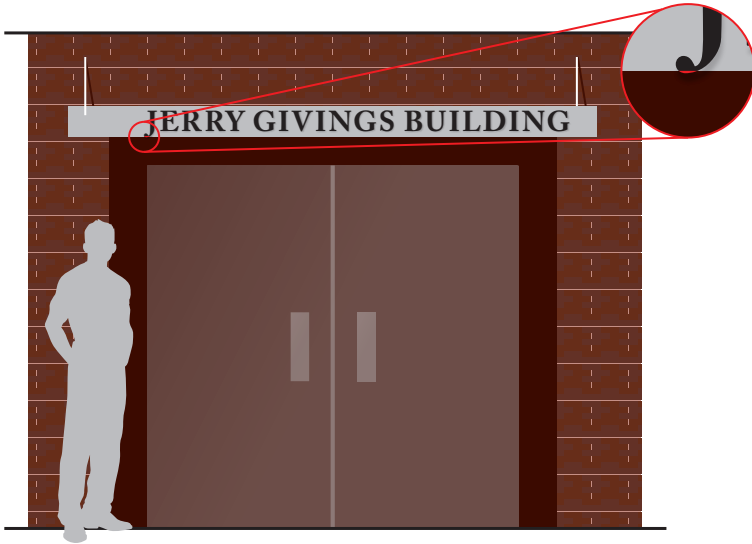

Consideration for Optimal Areas with Limited Space

Areas above an entrance (like canopies) are ideal for visibility in placement, but limitations of size may not accommodate size and typographic standards.

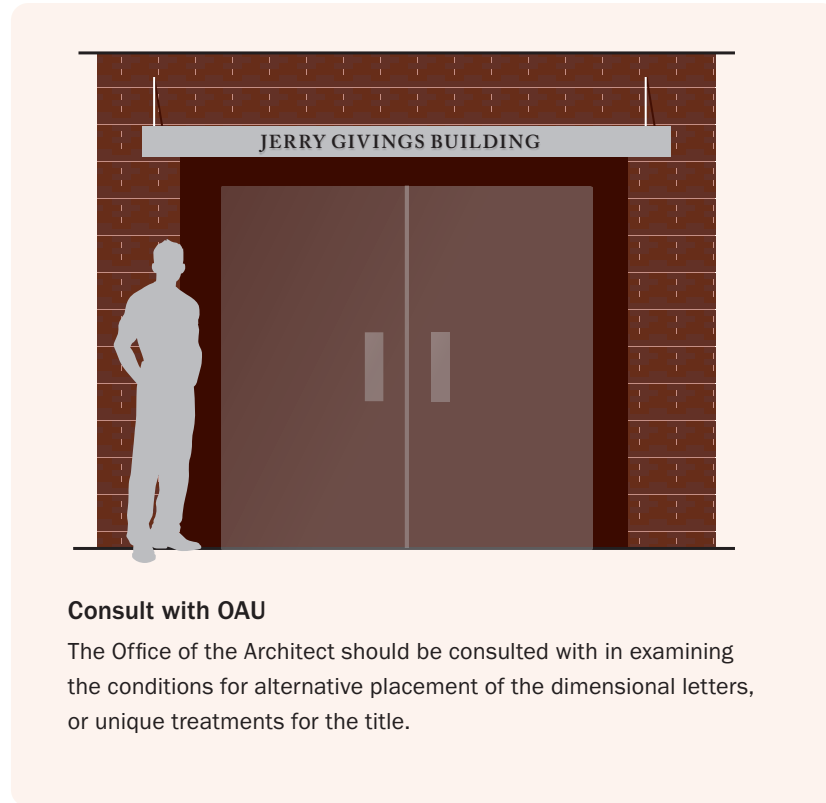

Consult with OAU

The Office of the Architect should be consulted with in examining the conditions for alternative placement of the dimensional letters, or unique treatments for the title.

Best Practices & 2025 Precedent

Building Dedication Plaques for Building Dedication

These engraved slate plaques give a contextual background to the values and missions behind the people of the building's namesake.

1. Collaboration Present content, site conditions, and proposal to OAU.

2. Content & Typography Content is written by the presiding school, and approved by the Office of the Architect and the Presidents Office. Ensure that the content is within the specified amounts, as exceeding content will not be approved. All content to be Adobe Caslon typeface, to layout specifications.

3. Materiality Plaque is made of a 2' by 2'-6" x 3/4" piece of Grayson Slate, honed finish, with 3/4" Hollywood Bevel edges is the only acceptable material for Building Dedication Plaques. All text is engraved 1/32" - 1/16" deep, and should receive a white satin infill.

4. Placement Plaques are to be placed on an interior wall, well-lit and immediately visible after entering the building. For drywall situations, blocking is essential to support the slate and must be confirmed prior to installation.

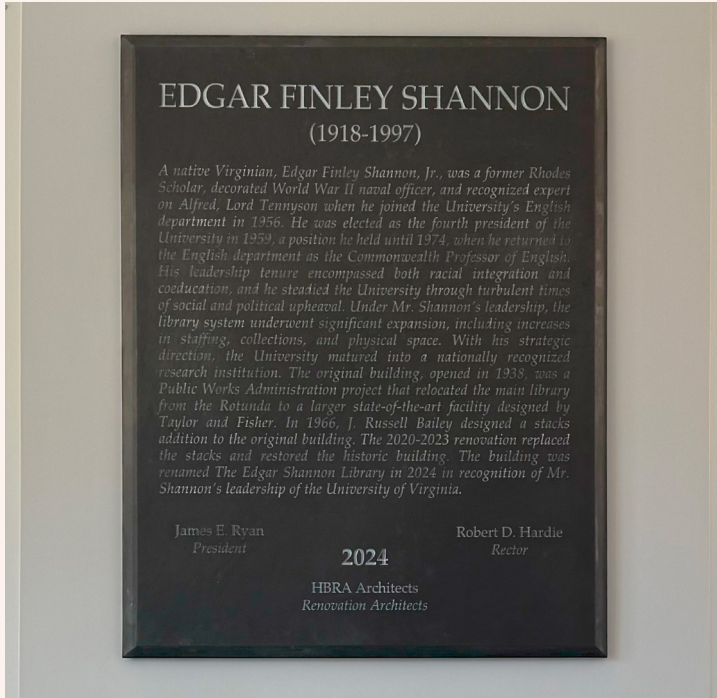

Example Precedent and Observations

This plaque, recognizing Edgar Finley Shannon of the Shannon Library namesake, is of UVA's standards for content amount, materiality, and indoor placement.

Content Guidance per Acknowledgement Type

Building Dedications | Building Dedicatory Plaque

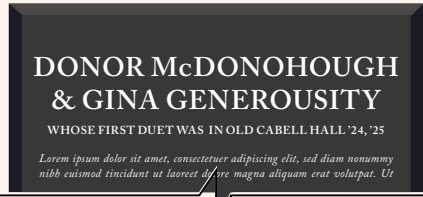

DONOR McDONOUGH & GINA GENEROSITY
 WHOSE FIRST DUET WAS IN OLD CABELL HALL '24, '25

Lorem ipsum dolor sit amet, consectetur adipiscing elit, sed diam nonummy nibh euismod tincidunt ut laoreet dolore magna aliquam erat volutpat. Ut

Recognition: SubHeader contains one-liner, graduated school, abbreviated years, etc.



CHARLES CAVALIER JR.
 "THE SHARPEST MINDS ARE ON OUR GROUNDS"

Lorem ipsum dolor sit amet, consectetur adipiscing elit, sed diam nonummy nibh euismod tincidunt ut laoreet dolore magna aliquam erat volutpat. Ut

Honorific: SubHeader is determined by the associated University parties.



VIRGINIA ISFORD-LOVE
 A GIFT FROM PHIL LOVE

Lorem ipsum dolor sit amet, consectetur adipiscing elit, sed diam nonummy nibh euismod tincidunt ut laoreet dolore magna aliquam erat volutpat. Ut

Tributary: Subheader must be used and have adequate room to acknowledge the donating party.



GEOFFREY THOMAS
 BELOVED PROFESSOR OF AMERICAN HISTORY
 0000 - 1234

Lorem ipsum dolor sit amet, consectetur adipiscing elit, sed diam nonummy nibh euismod tincidunt ut laoreet dolore magna aliquam erat volutpat. Ut

Memorial: Subheader must be used to acknowledge the years lived. Two lines may be appropriate to separate a description from years.



EXAMPLE NAME '25
STUDY BUILDING
 SCHOOL OF COMMERCE

Lorem ipsum dolor sit amet, consectetur adipiscing elit, sed diam nonummy nibh euismod tincidunt ut laoreet dolore magna aliquam erat volutpat. Ut

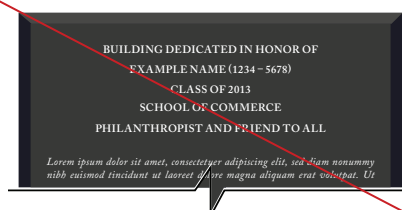

BUILDING DEDICATED IN HONOR OF
 EXAMPLE NAME (1234 - 5678)
 CLASS OF 2013
 SCHOOL OF COMMERCE
 PHILANTHROPIST AND FRIEND TO ALL

Lorem ipsum dolor sit amet, consectetur adipiscing elit, sed diam nonummy nibh euismod tincidunt ut laoreet dolore magna aliquam erat volutpat. Ut

Not to be Approved

The Acknowledgement should only identify the acknowledged party's name and not a class grad year, building name, or any other information.

Hierarchy between the Acknowledgement and SubHeader sizes are essential to disseminate content. Do not adjust layouts to accommodate more content.

Content Overview and Layout Anatomy 1/4

Building Dedications | Building Dedicatory Plaque

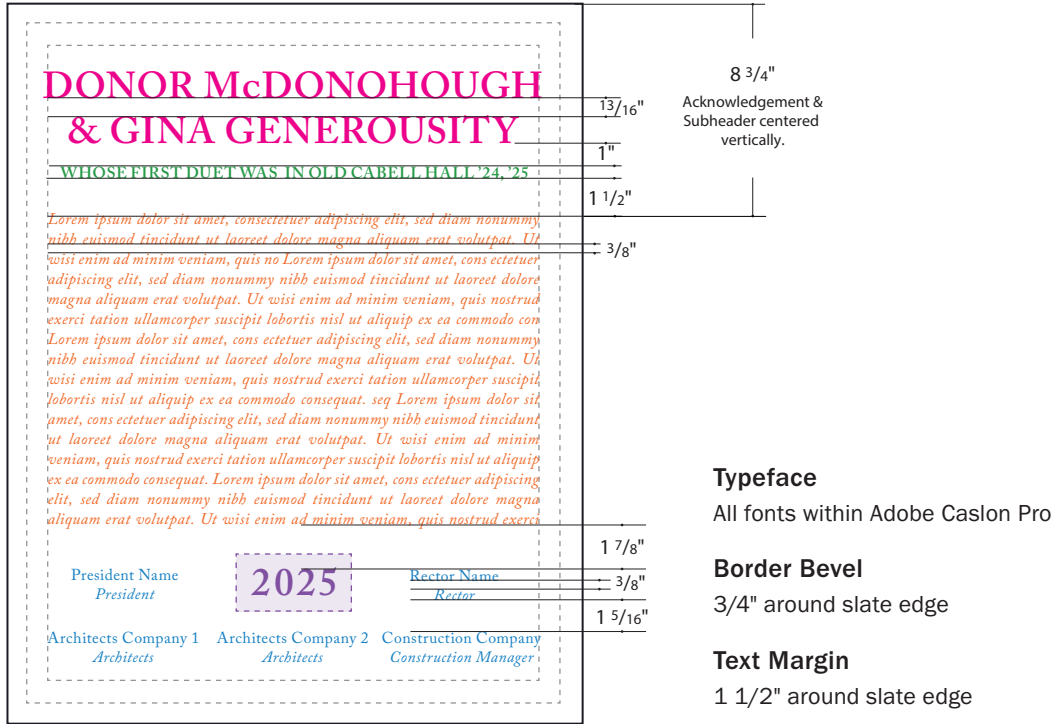

Acknowledgement: 1 1/8", 2 Lines, ~32 Characters
Semibold, Uppercase, Center-aligned

Subheader: 1/2", 1 Line, ~42 Characters
Semibold, Uppercase, Center-aligned

Paragraph Text: 1/2", 16 Lines, ~1,600 Characters
Italic, Sentence-Case, Justified-aligned

Dedication Year: 1 1/8"
Semibold, Uppercase, Centered on plaque
5/8" padding around edges

Credits: 1/4": Up 5 credits can fit
Italic and Semibold, Sentence-Case, Center-aligned, around Year

Measurements on diagram mark the distance between text elements.

Content Overview and Layout Anatomy 2/4

Building Dedications | Building Dedicatory Plaque

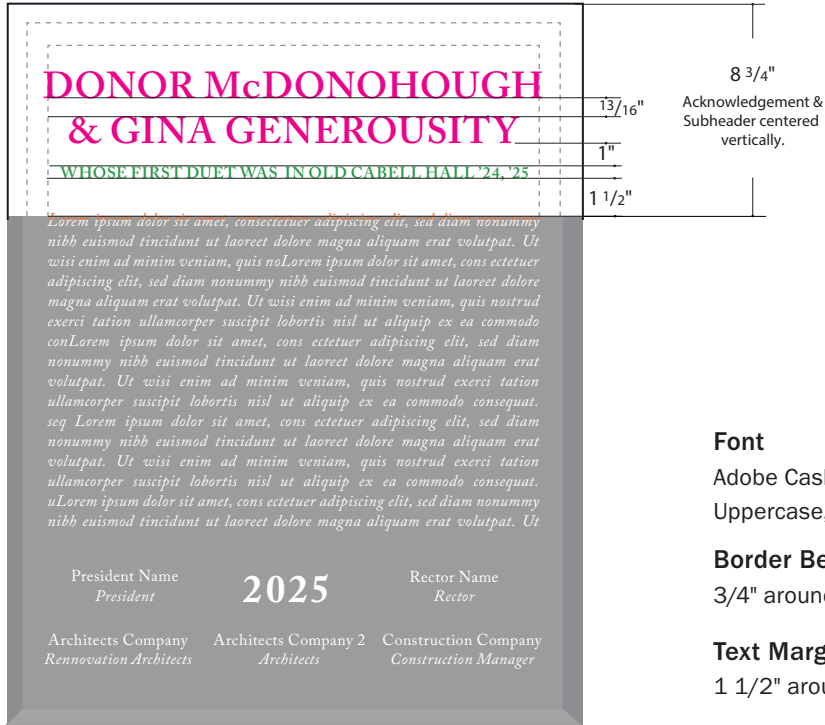

Acknowledgement: 1 1/8", 2 Lines, ~32 Characters

Includes full donor name. Leading statement indicates type of acknowledgement.

No grad years, or schools names to be included here.

In married couples, woman's name appears first.

Family names are to be combined to appear in single instance.

Amperasands "&" used when applicable.

No schools names are to be included.

Avoid middle names and middle initials.

Subheader: 1/2", 1 Line, ~42 Characters

May contain a one-liner description, quote, grad years, etc.

Any grad years are to be abbreviated in two digits.

Measurements on diagram mark the distance between text elements.

Content Overview and Layout Anatomy 3/4

Building Dedications | Building Dedicatory Plaque

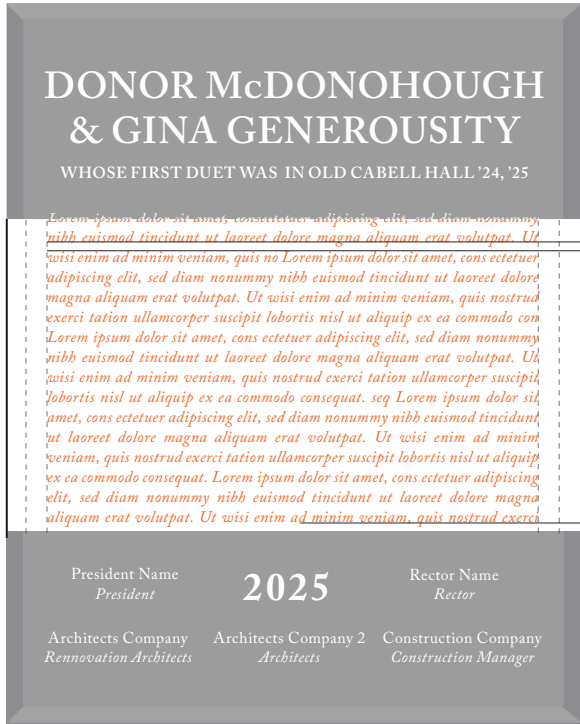

Font
 Adobe Caslon Pro Semibold.
 Uppercase, Center-aligned

Border Bevel
 3/4" around slate edge

Text Margin
 1 1/2" around slate edge

Paragraph: 1/2", 16 Lines, ~160 Words, ~1,600 Char.

This section gives context about the background and mission of the donating party(s) in association to their gift.

Paragraph Text Development Process

The content for the Building Dedication plaque is first written by its relating school, and afterwards approved by the OAU and President's Office. The affiliated donors/parties are to give input and approve the paragraph content. Donors should be made aware that adjustments which exceed the threshold of content limitations are unable to be made.

Measurements on diagram mark the distance between text elements.

Content Overview and Layout Anatomy 4/4

Building Dedications | Building Dedicatory Plaque

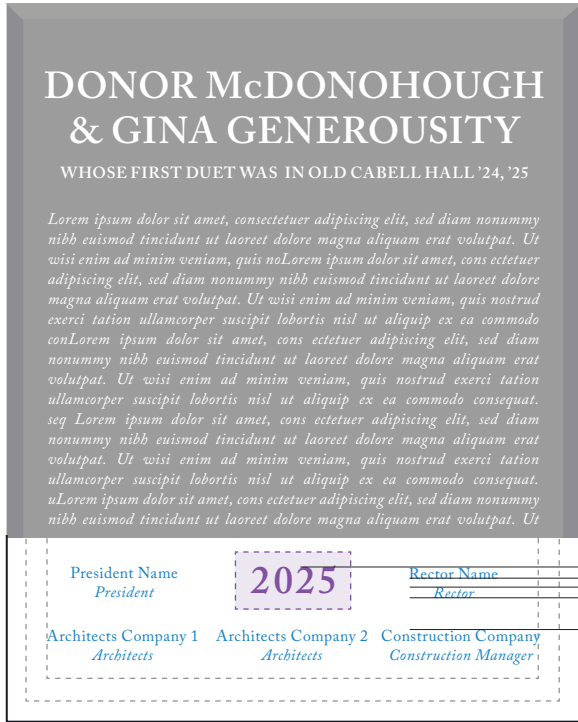

Font
 Adobe Caslon Pro Semibold.
 Uppercase, Center-aligned

Border Bevel
 3/4" around slate edge

Text Margin
 1 1/2" around slate edge

Measurements on diagram mark the distance between text elements.

Dedication Year: 1 1/8"
 Semibold, Uppercase, Centered on plaque
 5/8" padding around edges

Credits: 1/4": Up to 5 Credits
 Company Name Credit: Italic
 Job Title Credit: Semibold

Credits are equally and symmetrically placed around the Dedication Year.

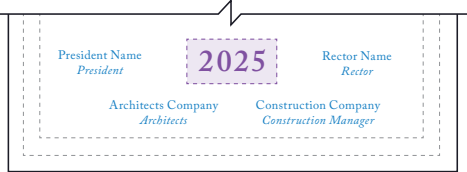

Example of centered layout of Credits for 4 Credits.

Materiality

Building Dedications | Building Dedicatory Plaque

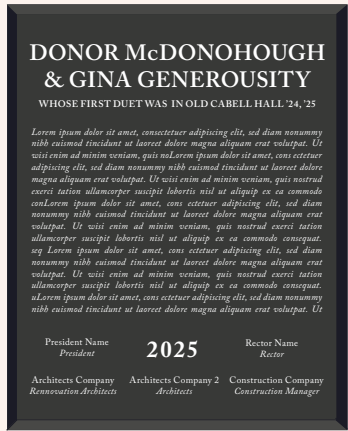

Engraved Slate

Plaques are a 3/4" thick Grayson Slate of honed finish, the outer 3/4" of the slate should have a 1/2" Hollywood bevel.

White Text Infill

All text is engraved 1/32" - 1/16" deep, and should receive a white satin infill.

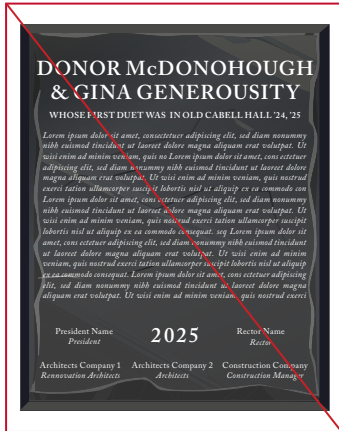

Not to be Approved

The Grayson slate plaque should have no finish other than smooth honed.

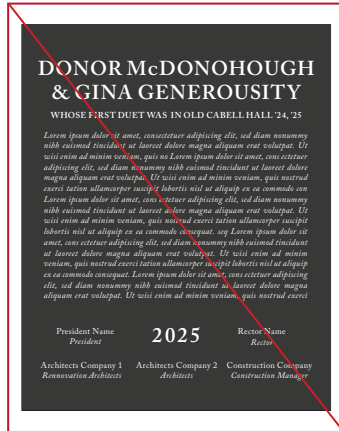

The Grayson slate plaque should not be straight cut, and always include the specified beveled edges.

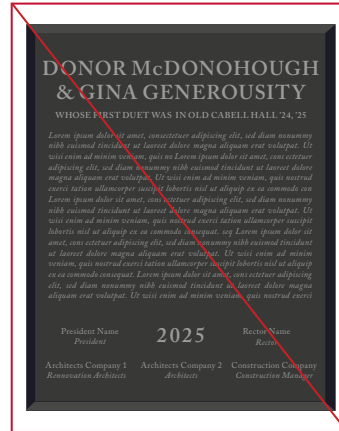

Grayson slate plaques

with differing engraved depth specifications or without white infill letters are unacceptable.

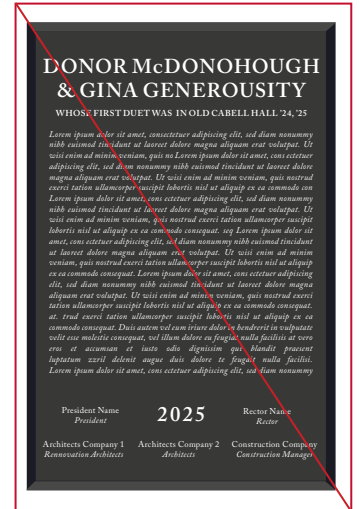

Alterations to size of plaque, text, or layout are not permitted.

Placement

Building Dedications | Building Dedicatory Plaque

Between 46" to 74"
Ideal Centered
Placement



Visible upon Building Entry

The preferred placement of a Building Dedication is immediately and obviously located inside the building they relate to.

Clear and Illuminated Position

Ensure that the Building Dedication Plaque is positioned in such a way that it will not be obscured by other features. Additionally, the plaque should be placed in a well-lit area rather than a shaded one. Additional spotlighting may be considered.

Within Range of Placement Height

While 60" on center is the ideal placement height, the range is given to accommodate an alignment with nearby architectural features.

It is appropriate that this sign should be higher than any room signs in the same area.

Consideration for Exterior Placement

Building Dedications | Building Dedicatory Plaque

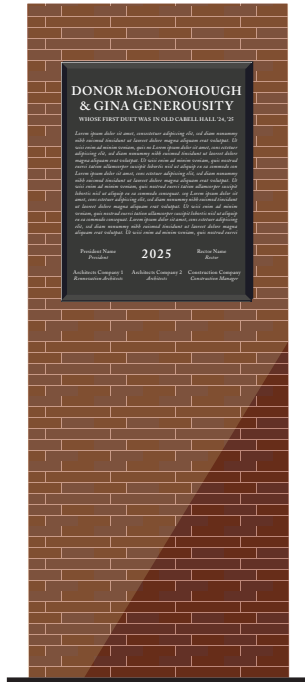

Placement on Exterior Only if Necessary
 Interior placement is always preferred.

If circumstances require placing the plaque on the exterior of the building, ensure that the plaque is placed in a well-lit area and within proximity to a primary entrance.

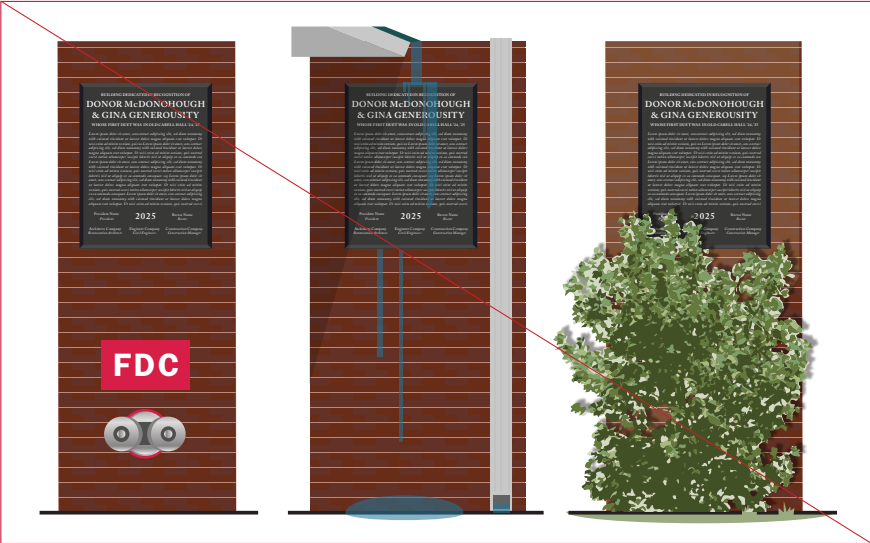

Not to be Approved

Under no circumstances should the Building Dedicatory Plaque be placed in dark corners, above fire and maintenance equipment, roof endings, gutters, nor behind any obstacles.

Building Dedicatory Plaque Material Notes

Building Dedications | Building Dedicatory Plaque

Grayson Slate

This stone, mined from Virginia's Arvonja Quarry, is the standard and traditionally-used material for Building Dedicatory Plaques

The stone is specified as 2' x 2'6" x 3/4" or 2 cm thick Grayson Slate slab, cut to size.

Face is smooth honed.

The outer edge are to be have a "Hollywood Bevel" style 3/4".

Letter Copy Decoration

Sand carved, 1/32" - 1/16" deep (shallow blast).

Text contains a white satin paint infill from Matthews Paint Company or similar product equivalent.

Mounting Mechanism

Blocking to be coordinated / confirmed in desired location prior to placement.

Stud mount flush to existing wall with & sealed in place with silicone or structural adhesive.

Studs are 1/3-20 threaded, and placed 3" on center.

Alternative Material Considerations

Any material not listed, but desired for its qualities, must be assessed by the Office of the Architect.

Consider cost, maintenance, and accordance with surrounding environmental conditions and architecture.

Proposed material samples should be procured and examined in their desired landscape.

Plaque for Undedicated Buildings

Building Dedications | Building Undedicated Plaque for ID



Use Case

An undedicated building is one available for dedication, but has not yet found an associated name to tie to. The signage application for these instances follows the same material and installation method of the Building Dedicatory Plaque, but differs in size and layout.

The Undedicated Plaque uses an identification in the title location where the acknowledgement would be.

Measurements on diagram mark the distance between text elements.

Plaque for Undedicated Buildings

Building Dedications | Building Undedicated Plaque



Identification: $1 \frac{1}{8}"$, 2 Lines, ~32 Characters
Semibold, Uppercase, Center-aligned

Credits: $\frac{1}{2}"$: Up 5 credits can fit
Italic and Semibold, Sentence-Case, Center-aligned, around Year

Dedication Year: $1 \frac{1}{8}"$
Semibold, Uppercase, Centered on plaque
 $\frac{5}{8}"$ padding around edges

Measurements on diagram mark the distance between text elements.

5

Civic Features

Civic Dedicatory Plaque

Plinth-Mounted Option

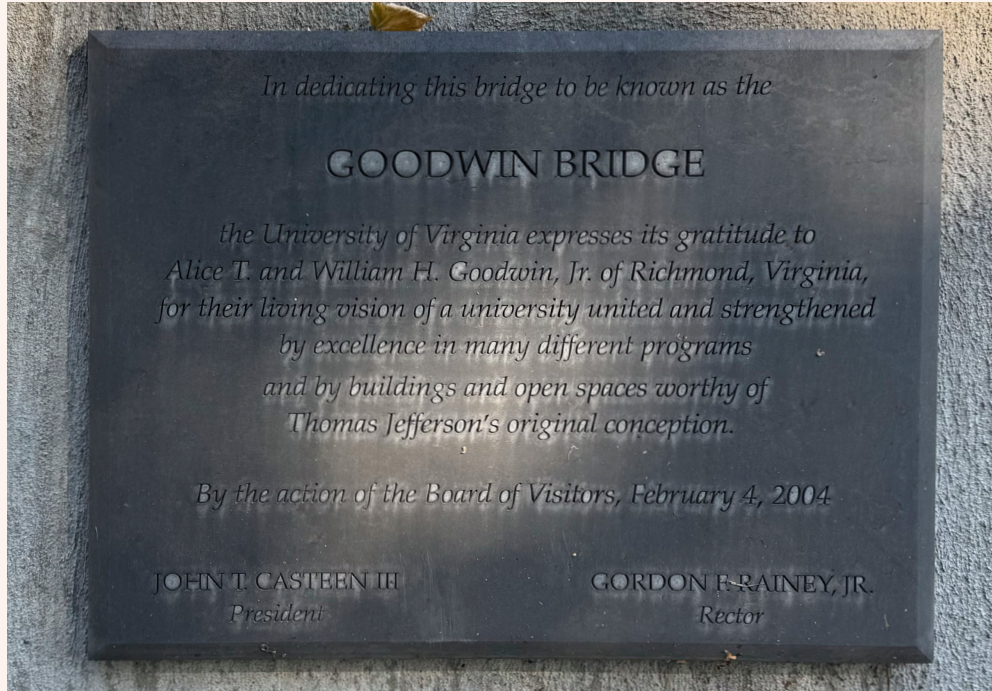

Example Precedent and Observations

The honorific Goodwin Bridge sets precedent for the scale of a Civic Feature, as well as the need for written copy to describe the situational context for dedication. This example's layout and infill is not to standard, however.

Best Practices & 2025 Precedent

Civic Dedicatory Plaques for Civic Features

Civic Features are major sections of grand construction. It differs from a featured space by a higher magnitude of cost, significance, and scale within the University's landscape. These engraved slate plaques give a contextual background to the values and missions and of the people of the feature's purpose and namesake.

- 1. Collaboration** Present content, site conditions, and proposal to OAU.
- 2. Content & Typography** Content is written by the presiding school, and approved by the Office of the Architect and the President's Office. Ensure that the content is within the specified amounts, as exceeding content will not be approved. All content to be Adobe Caslon typeface, to layout specifications.
- 3. Materiality & Design** A 2' x 1'4" Grayson Slate plaque, of honed finish, and with 3/4" Hollywood Bevel edges is the only acceptable material for Civic Dedicatory Plaques. All text is engraved 1/32" - 1/16" deep, and should receive a white satin infill.
- 4. Placement** Plaques may be wall-mounted or on a stand-alone masonry plinth which, in consultation with the OAU, matches the hardscape of its surrounding area. Plaques are to be placed at a height between 46" to 72", in an area which encourages its reading, and within the vicinity of the feature they identify.

Sign Type Applications

Civic Features

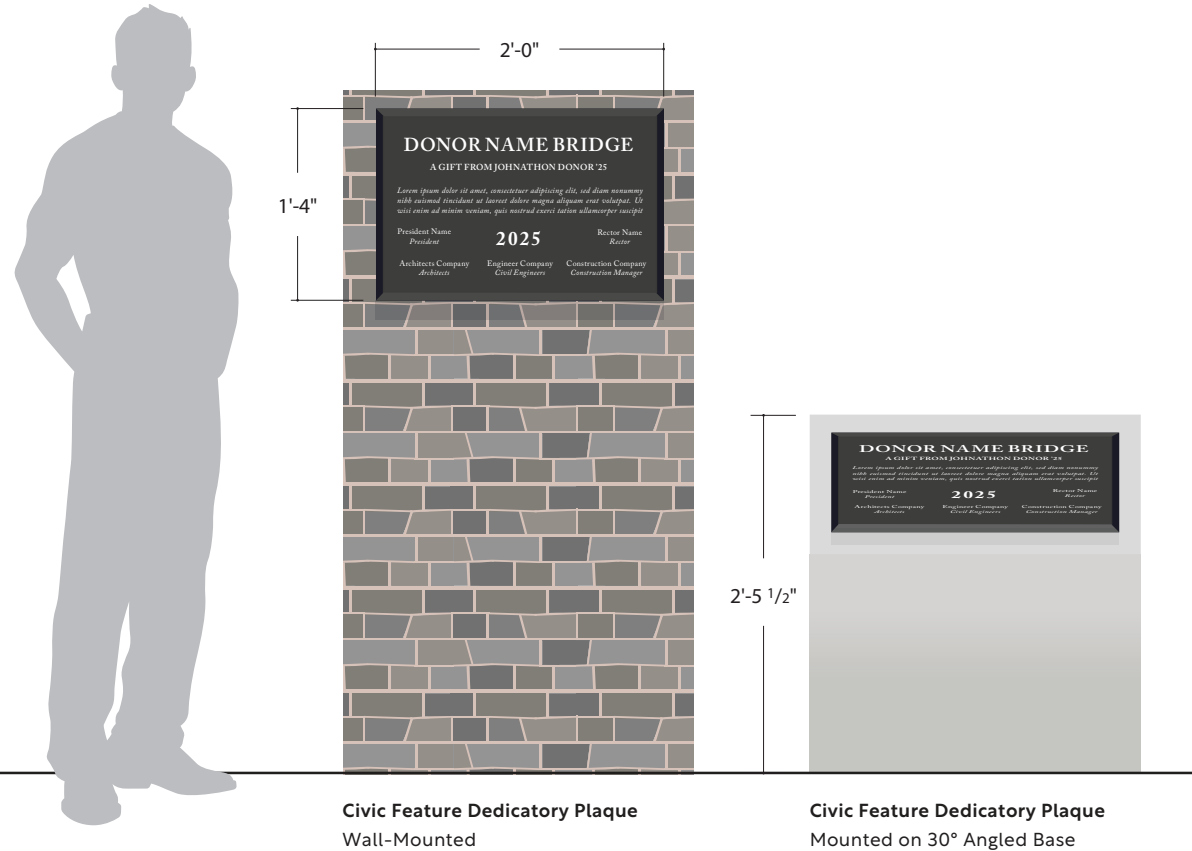

Civic Feature Dedicatory Plaque
Wall-Mounted

Civic Feature Dedicatory Plaque
Mounted on 30° Angled Base

Content Overview and Layout Anatomy 1/4

Civic Features | Dedicatory Plaque

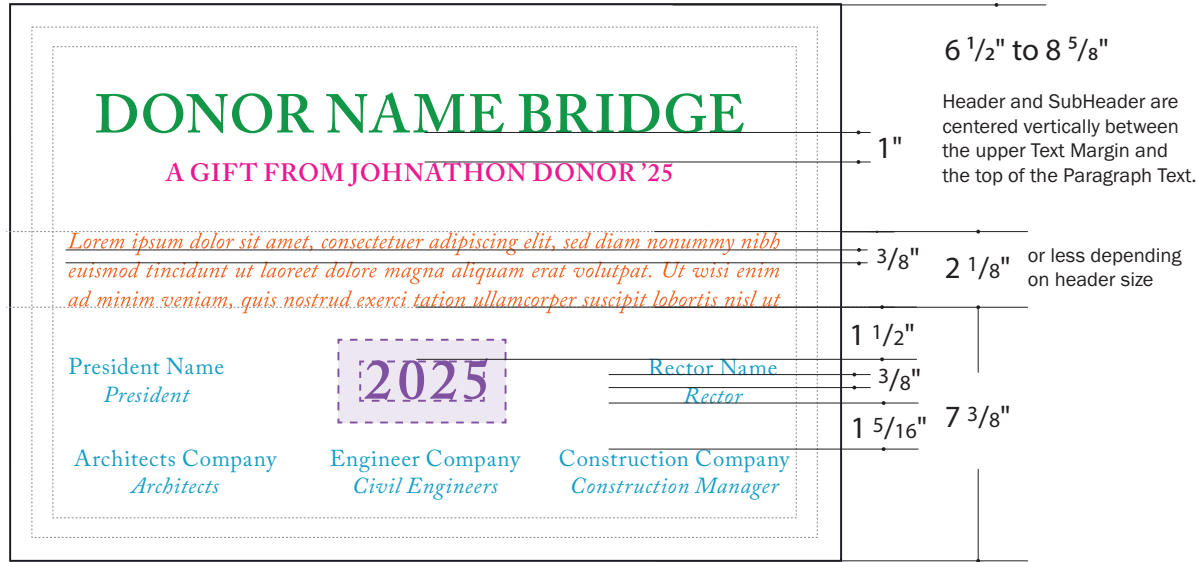

Measurements on diagram mark distance between elements and section blocks

Border Bevel

3/4" around slate edge

Text Margin

1 1/2" around slate edge

Identification: 1 1/8", 1 to 2 Lines, ~60 Char.
Semibold, Uppercase, Center-aligned

Acknowledgement: 1/2", 1 to 2 lines, ~80 Char.
Semibold, Uppercase, Center-aligned

Paragraph: 1/2", 1 to 3 lines, ~74 to ~222 Char.
Italic, Sentence-case, Justify-aligned

Dedication Year: 1/2"
Semibold, Uppercase, Centered in plaque
5/8" padding around edges

Credits: 1/2": 5 Count
Semibold and Italic, Sentence-case
Equally spaced around Dedication Year

Content Overview and Layout Anatomy 2/4

Civic Features | Dedicatory Plaque



Identification: 1 1/8", 1 to 2 Lines, ~36 Char.
 Semibold, Uppercase, Center-aligned

Identification uses donor name if acknowledgement is Dedication.
 Concise format – dedications do not need full "legal" name here.
 No grad years, or schools names to be included here.

Acknowledgement: 1/2", 1 to 2 lines, ~80 Char.
 Semibold, Uppercase, Center-aligned

Includes full donor name. Leading statement indicates type of acknowledgement.

Grad year to be abbreviated in two digits.
 In married couples, woman's name appears first.
 Family names are to be combined to appear in single instance.
 Ampersands "&" used when applicable.
 No schools names are to be included.
 Avoid middle names and middle initials.

Measurements on diagram mark distance between elements and section blocks

Border Bevel

3/4" around slate edge

Text Margin

1 1/2" around slate edge

Content Overview and Layout Anatomy 3/4

Civic Features | Dedicatory Plaque

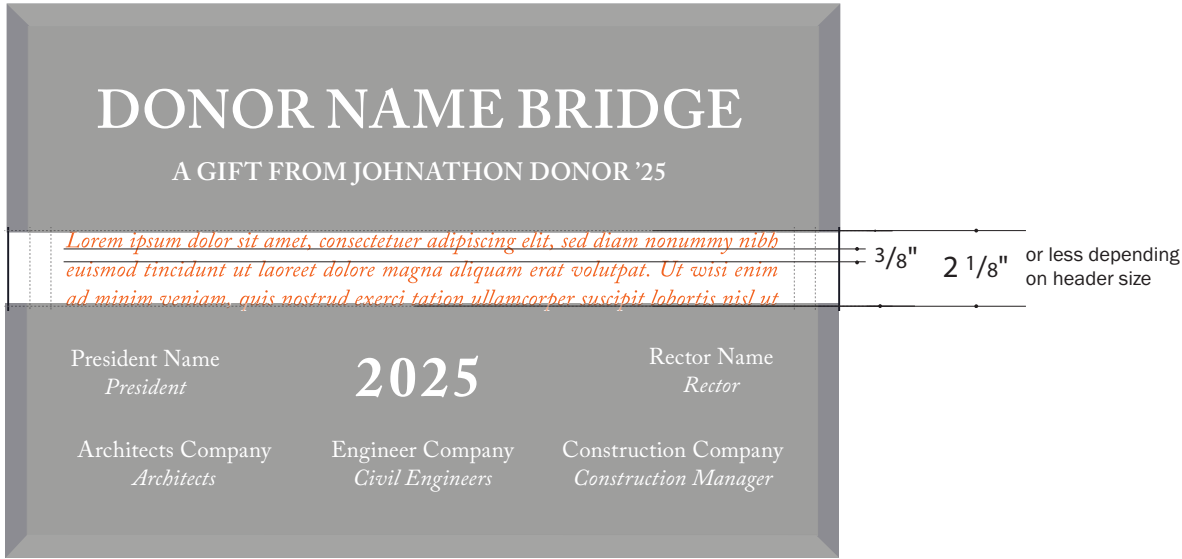

Measurements on diagram mark distance between elements and section blocks

Border Bevel

3/4" around slate edge

Text Margin

1 1/2" around slate edge

**Paragraph: 1/2", 1 to 3 lines,
~74 to ~222 Char.**

This section gives context about the background and mission of the donating party(s) in association to their gift.

Paragraph Text Development Process

The content for the Building Dedication plaque is first written by its relating school, and afterwards approved by the OAU. The affiliated donors/parties are to give input and approve the paragraph content.

Donors should be made aware that adjustments which exceed the threshold of content limitations are unable to be made.

Content Overview and Layout Anatomy 4/4

Civic Features | Dedicatory Plaque



Measurements on diagram mark distance between elements and section blocks

Border Bevel

3/4" around slate edge

Text Margin

1 1/2" around slate edge

Dedication Year: 1 1/8"

Semibold, Uppercase, Centered on plaque
5/8" padding around edges

Credits: 1/4": Up to 5 Credits

Company Name Credit: Italic
Job Title Credit: Semibold

Credits are equally and symmetrically placed around the Dedication Year.

Content Guidance per Acknowledgement Type

Civic Features | Dedicatory Plaque



Recognition: Acknowledgement uses "A GIFT FROM", followed by donor name.



Honorific: Acknowledgement uses "IN HONOR OF", followed by donor name.



Tributary: Acknowledgement uses "A GIFT FROM", followed by donor name as well as "IN HONOR OF" or "IN MEMORY OF" the tribute party.



Memorial: Acknowledgement uses either "IN MEMORY OF", or the memorialized person & years lived in parentheses, and info. Memorials themselves may be an identified location.

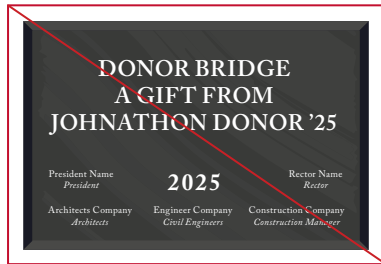
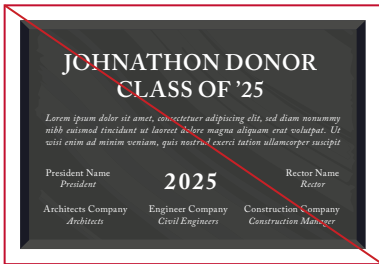

Not to be Approved

The headline should only identify the feature as it is named, and not be used for the acknowledged party's name.

Hierarchy between Identification and Acknowledgement sizes are essential to disseminate content. Do not use one size for two types of content.

Concise Content Consideration

Civic Features | Dedicatory Plaque



Content Reassessment



Consideration for Concise Content

Should both the Identification and the Acknowledgement text sections reach their maximum of two lines each, it is appropriate for the Inscription Content to be reduced line-by-line to uphold plaque size standards.

If more of the Inscription Content is desired, the identification or acknowledgement content may be reassessed.

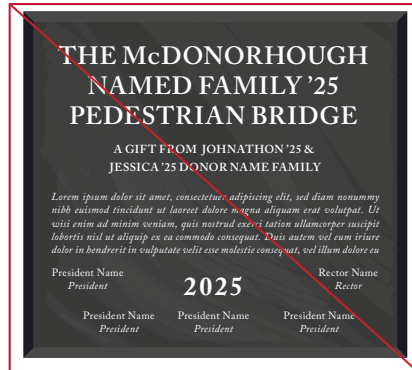
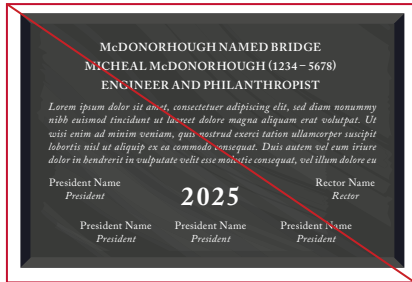

Not to be Approved

The type size of the Identification and Acknowledgement are not to be adjusted or matched order to accommodate longer titles or more content.

Under no circumstances should the plaque size be increased.

Wall Placement

Civic Features | Dedicatory Plaque

Between 46" to 74"
Ideal Centered
Placement

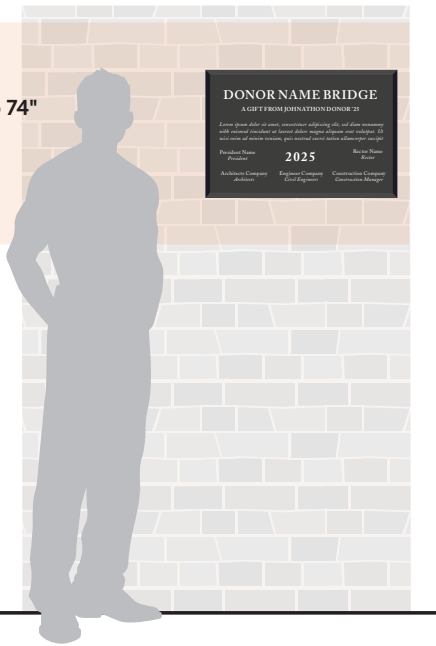

Visible upon Entering Vicinity

The preferred placement of a Civic Dedicatory plaque is immediately and obviously located at the beginning of the feature or space they relate to.

Secure and Illuminated Position

Ensure that the Civic Dedicatory Plaque is positioned in such a way that it will not be obscured by other features. Additionally, the plaque should be placed in a well-lit area rather than a shaded one, or one that would receive debris from above. Angled surfaces make reading the plaque from a lower height a bit easier.

Within Range of Placement Height

While 60" on center is the ideal placement height, the range is given to accommodate an alignment with nearby architectural features.

Civic Dedicatory Plaque Material Notes

Civic Features | Civic Dedicatory Plaque

Grayson Slate

This stone, mined from Virginia's Arvonja Quarry, is the standard and traditionally-used material for Building Dedicatory Plaques

The stone is specified as a 2' x 14" x 3/4" or 2 cm thick Grayson slate slab, cut to size.

Edges are to be have a "Hollywood Bevel" style 3/4".

Letter Copy Decoration

Sand carved, 1/32" - 1/16" deep (shallow blast).

Copy contains an infilled with a White Satin MAP from Matthews Paint Company.

Mounting Mechanism

Exact process to be confirmed with OAU prior to placement.

Stud mount flush to masonry wall & seal with exterior grade silicone.

Studs are 1/3-20 threaded, and placed 3" on center.

Alternative Material Considerations

Any material not listed, but desired for its qualities, must be assessed by the Office of the Architect.

Consider cost, maintenance, and accordance with surrounding environmental conditions and architecture.

Proposed material samples should be procured and examined in their desired landscape.

6

Exterior Spaces & Promenades

Bluestone Paver Integrations

Vertical Plaque Integrations

Sign Type Overviews

Exterior Spaces & Promenades



Large Paver

For use large courtyards, plazas, and centralized gathering spaces.



Small Paver

For smaller gardens & courtyards, as well as promenade and pathways.



Exterior Feature ID

Only to be used if conditions favor a wall-mounted treatment over the paver options.



Example Precedent and Observations

This example showing Boots Plaza correctly incorporates the size of a flame-treated paver with the surrounding hardscape, and also shows an effort to employ tooled joints around the paver, but is not well executed and lacks a border incorporation.



Garden VI is an example which shows how a paver identifies both the space and the donor recognition. The paver is to an appropriate scale to its endowed space, and incorporates a border which matches the surrounding pavement material.

Best Practices & 2025 Precedent

Exterior Spaces & Promenades

Bluestone pavers are the ideal medium of acknowledgement for exterior spaces, with some considerations depending on site conditions alternatives. Criteria for OAU Approval is as follows:

- 1. Coordination** Present all site, conditions and designs to OAU.
- 2. Content** The paver should identify the space it relates to above the recognized donor name. All content is of layout standards.
- 3. Materiality** Pavers are thermally-finished "True Blue" bluestone with shadow infill on the engraved letters. The depth of the paver should respond to the uses of the path / area it is placed into.
- 4. Design** Pavers are rectilinear in shape, their size is appropriate to their environment, and the standard of use case and layout guidelines. All pavers are integrated into their surrounding pavement both in size, shape, and with the incorporation of a running brick .
- 5. Placement** The placement of pavers is dependant on the type of space it distinguishes. Pathways and promenades will receive a different treatment for placement than open areas and courtyards.

Bluestone Paver Use Cases

Exterior Spaces & Promenades | Bluestone Pavers

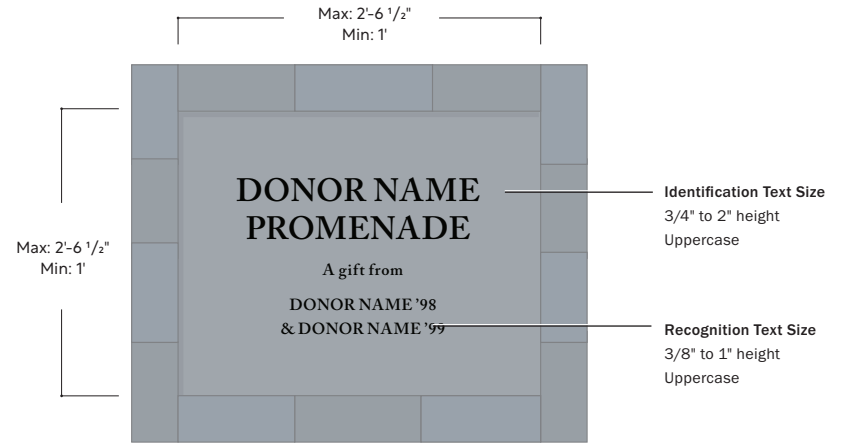
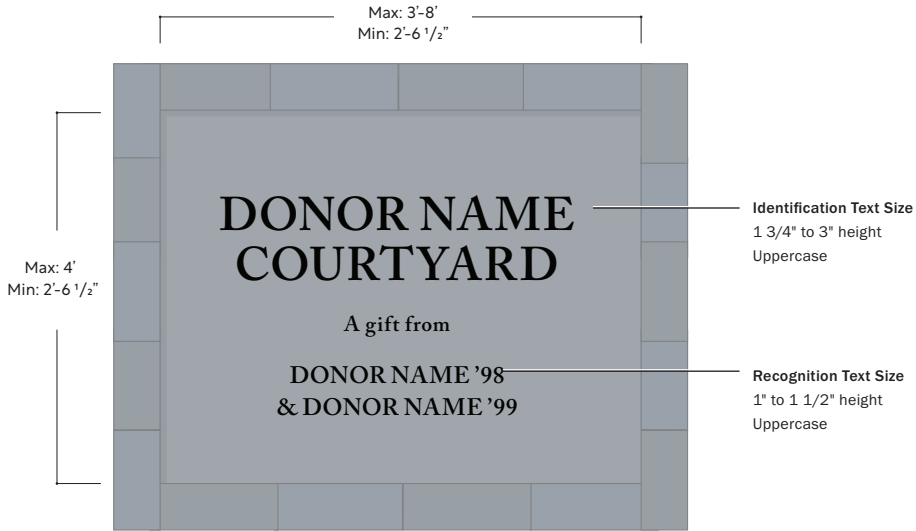

Large Pavers for Open Areas & Centralized Gathering Spaces

Such as large courtyards, plazas, and terraces.

Usually will be singular in count.

Small Pavers for Enclosed Areas & Promenades

Such as gardens, promenades, and paths.

May be multiple in count to reinforce path identification.

Content Overview and Layout Anatomy 1/3

Exterior Spaces & Promenades | Bluestone Pavers

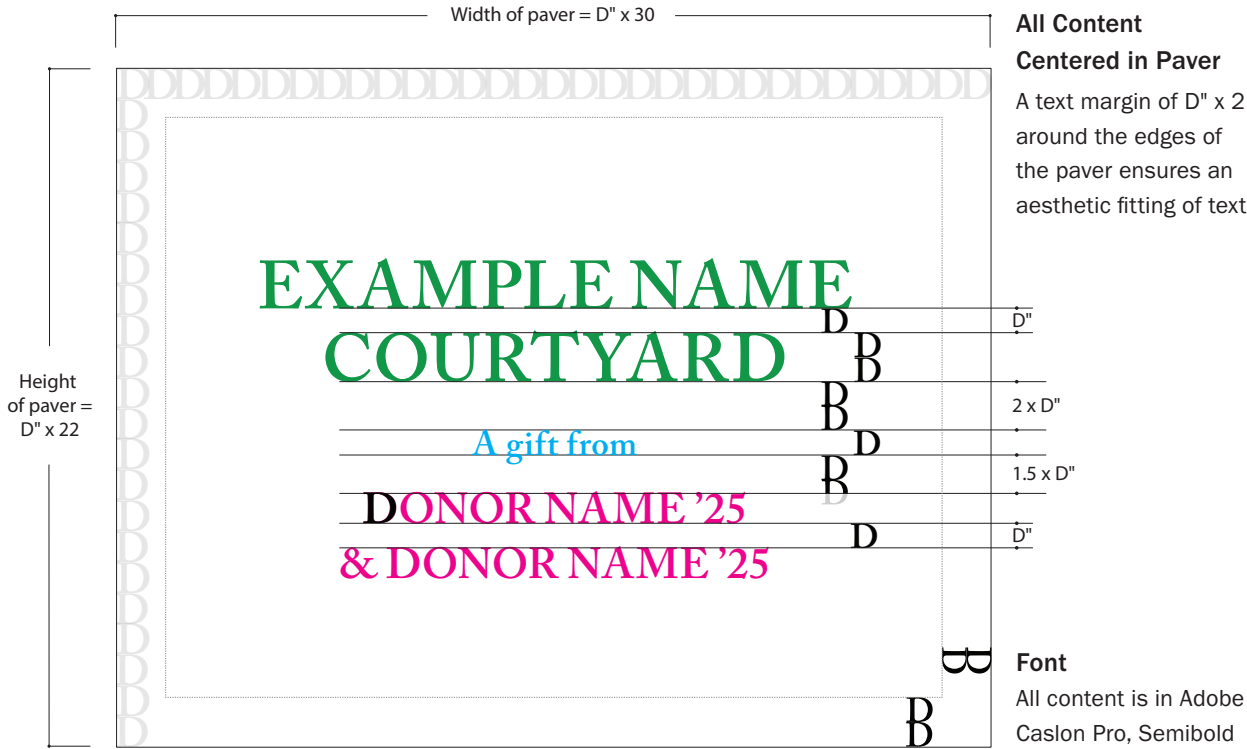

Paver Size or Letter Size as Layout Guide

The allotted size of the paver (or the desired size of the recognition) can be used to determine the proportions of the rest of the signs.

This a starting reference and may be adjusted or feasibility. Rounding up or down to nearest $1/8$ " metric is permitted. Letters should not be smaller than $1/4$ " for engraving purposes.

Identification = $D \times 2$, 1 to 2 lines, 30 char.

Uppercase, Center-aligned

Byline = D ", 1 line

Sentence-Case, Center-aligned

Acknowledgment = D ", 1 to 2 lines, 50 char.

Uppercase, Center-aligned

Content Overview and Layout Anatomy 2/3

Exterior Spaces & Promenades | Bluestone Pavers

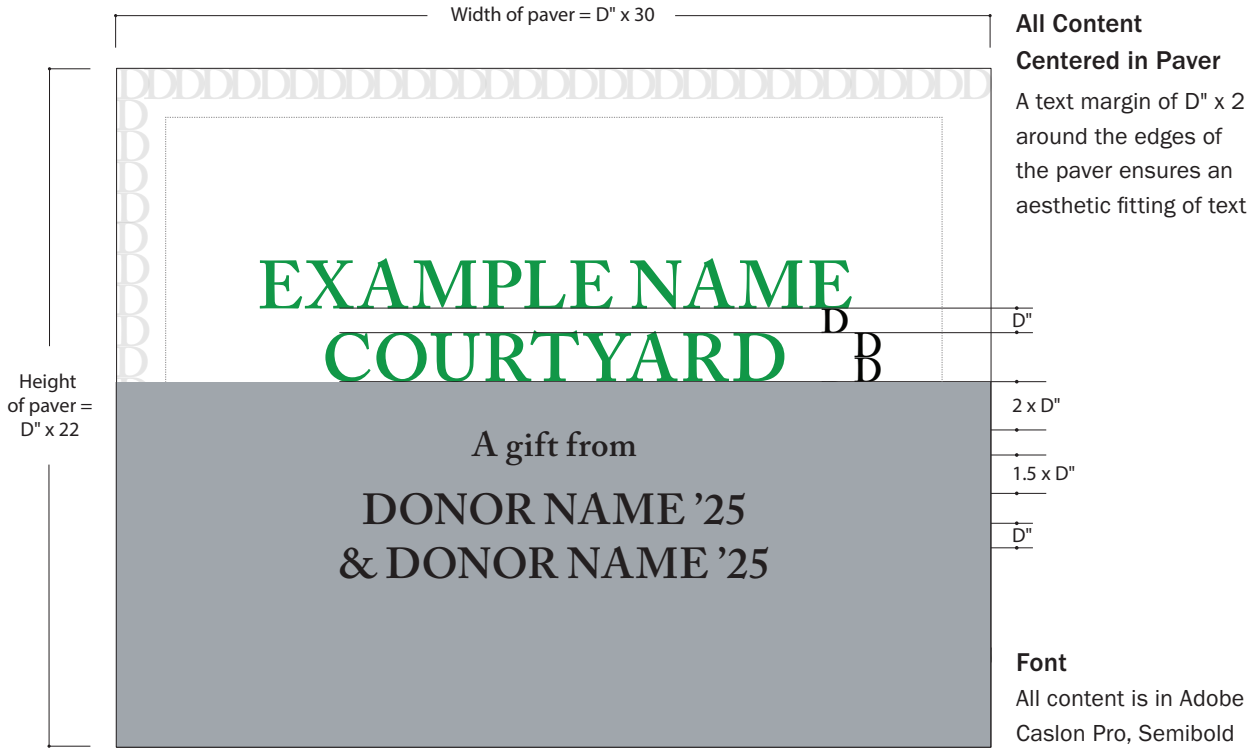

Identification = $D'' \times 2$, 1 to 2 lines, 30 char.
 Uppercase, Center-aligned

Identification uses donor name if acknowledgement is a Dedication.
 No grad years, or schools names to be included here.
 Concise format – dedications do not need full "legal" name here.

Measurements on diagram mark distance between elements and section blocks

Content Overview and Layout Anatomy 3/3

Exterior Spaces & Promenades | Bluestone Pavers

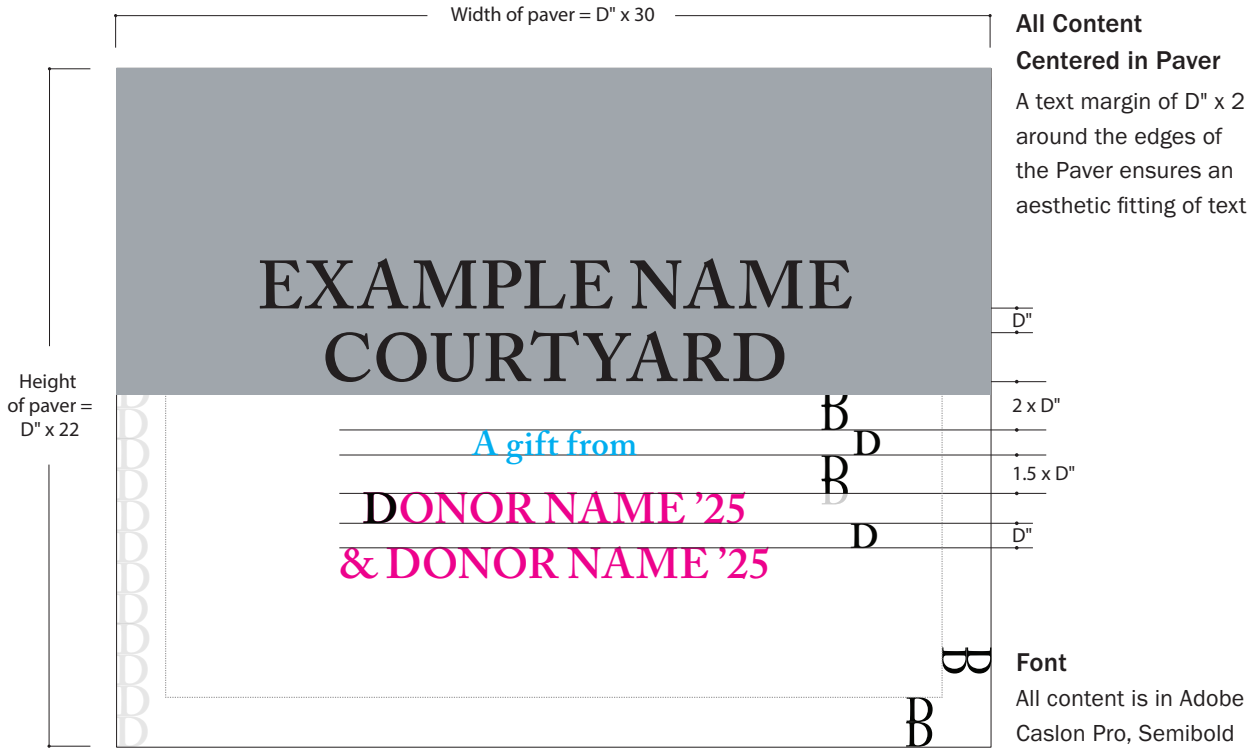

Measurements on diagram mark distance between elements and section blocks

Content Guidance per Acknowledgement Type

Exterior Spaces & Promenades | Bluestone Pavers

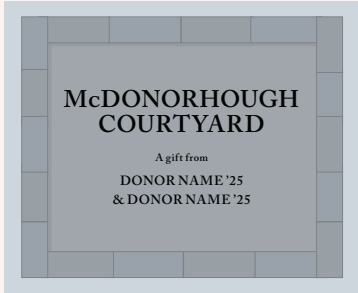

Recognition: Byline uses "A GIFT FROM", followed by donor name.

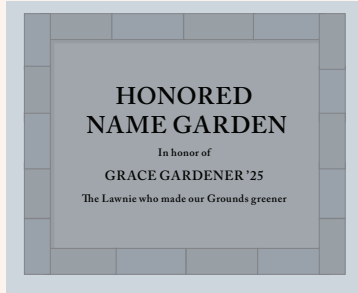

Honoric: Byline uses "IN HONOR OF", followed by donor name. It is appropriate for another Byline-format text underneath the honored party for quote or context line.

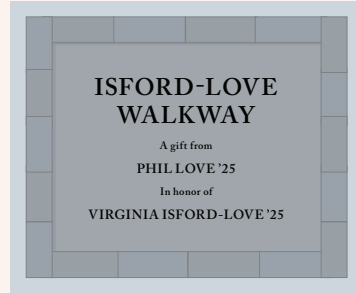

Tributary: Byline uses "A GIFT FROM", followed by donor name as well as "IN HONOR OF" or "IN MEMORY OF" the tribute party.

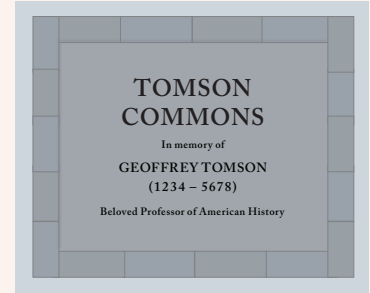

Memorial: Byline uses "IN MEMORY OF". It is appropriate for another line of Recognition-format text for years lived.

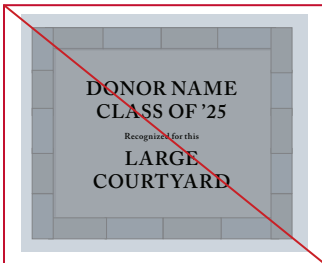

Not to be Approved

The Identification should only identify the feature as it is named, and not be used for the acknowledged party's name.

Hierarchy between the Identification and Acknowledgement text sizes are essential to disseminate content. Do not use one size for two types of content or adjust layout in any regard.

Materiality

Exterior Spaces & Promenades | Bluestone Pavers

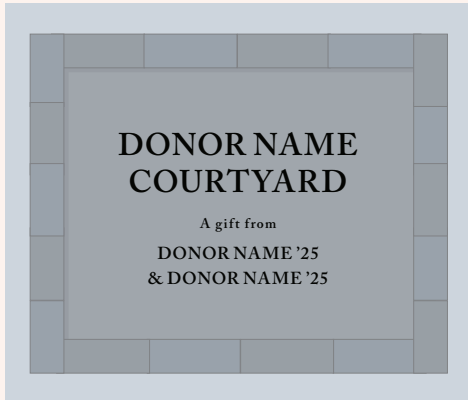

Color and Finish

Bluestone is available in many different colors. The standard for acknowledgement pavers is known as a "Blue-Blue", "True Blue" or "Select Blue".

The paver is to have a thermally-finished surface to assist footing grip.

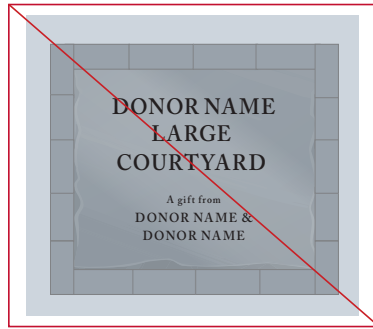

Not to be Approved

Natural clefts, tumbled, finishes other than thermal-treated are not acceptable.

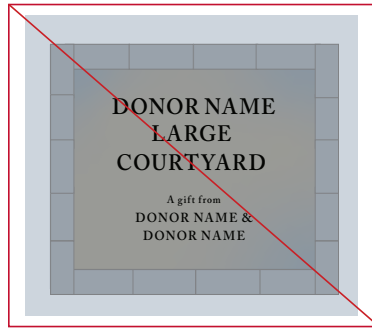

Bluestone colors other than solid "Blue-Blue" are not acceptable.

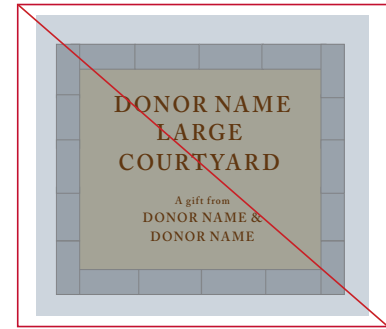

Materials other than "Blue-Blue" Bluestone are not acceptable.

Letter Engraving Depth

Letters are to be sand carved, 3/16" to 1/8" deep. A simple dark shadow-colored infill may be appropriate for legibility within the letters.

Consult with OAU for Alternative Materials

Existing paver spaces may be made of different paving materials. In these instances it is appropriate to match the landscape rather than introducing Bluestone. Consult with the OAU to best match the landscape.

Design and Border Incorporation

Exterior Spaces & Promenades | Bluestone Pavers

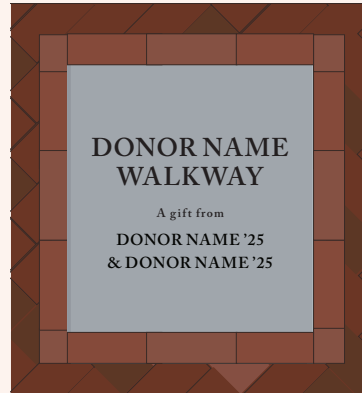
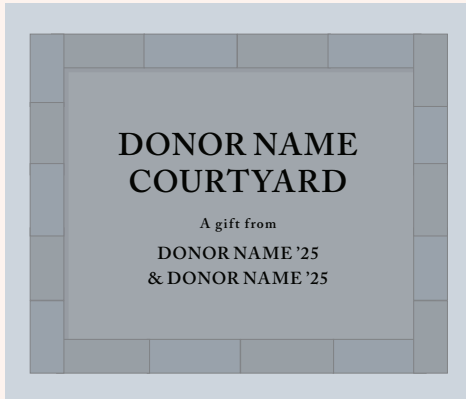

Paver to be Rectilinear

All pavers are to be either a horizontal or vertical rectangle shape, whichever is best incorporated into the surrounding pavers.

Sealed Border Incorporation Needed

A running bond brick band border must be included with the paver. The border and paver must be set into a mortar bed for durability. If paver set in concrete paving, a brick border may be used if appropriate. Otherwise, tooled joints shall be used around the paver.

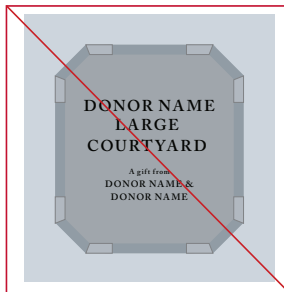
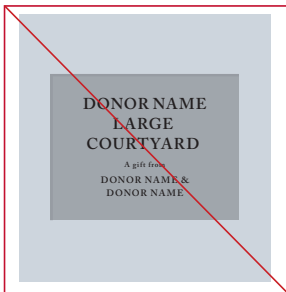

Not to be Approved

No pavers are to be installed without specified border or tooled joints.

Pavers must be rectilinear in shape, unless a variation to match the surrounding environment is approved by the OAU.

Paver Depth and Setting Bed

Exterior Spaces & Promenades | Bluestone Pavers

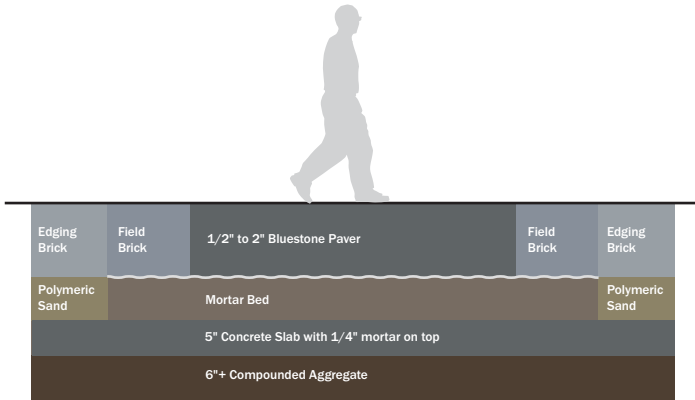

Pedestrian Paths: 1 1/2" to 2" Thick

Paths on Grounds which are pedestrian-use may use a thinner paver. Always confirm conditions with a paving specialist, facilities management, and the OAU. Pavers with larger surface area may need to be on the thicker end of the range as well.

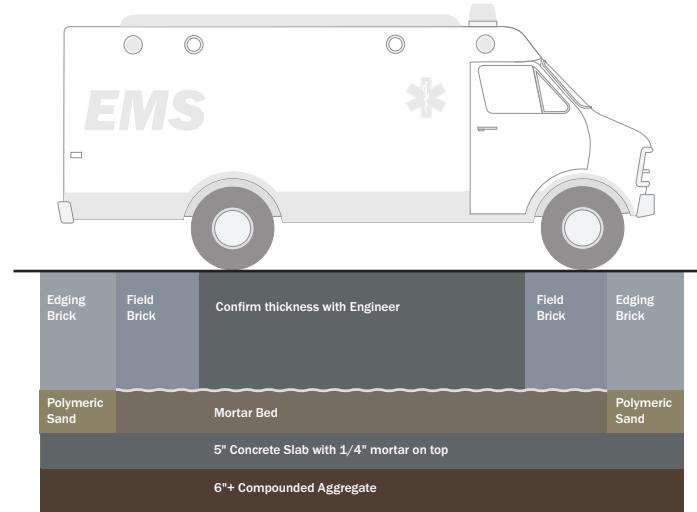

Vehicular-Used Paths: Confirm Thickness with Engineer

Many paths on Grounds may be used by heavy EMS, fire, or emergency vehicles. In these instances, a paver that is thinner in depth can crack under pressure, so a thicker depth of paver should be considered. Pavers with larger surface area may need to be on the thicker end of the range as well.

Applications for Long Pathways

Exterior Spaces & Promenades | Bluestone Pavers

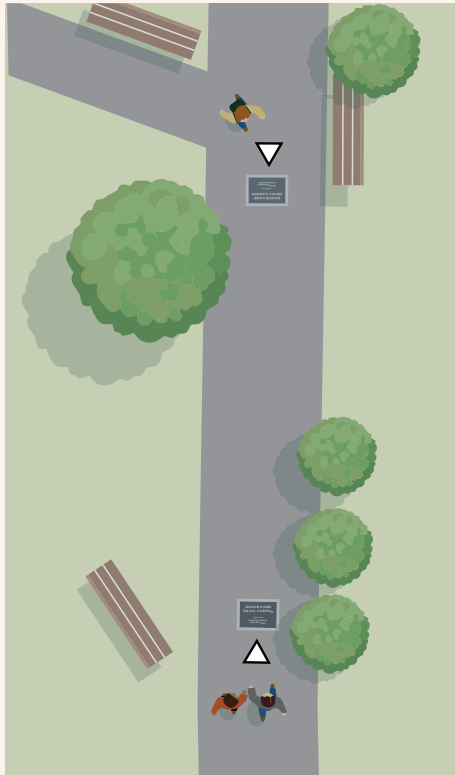

x2

Recommended

For exterior walkways, promenades, and paths, pavers should be the preferred recognition sign type. A multiple count of pavers at a modest size can identify the pathway at key points.

Place pavers at beginning and ends of the walkway, as well as at any major intersections

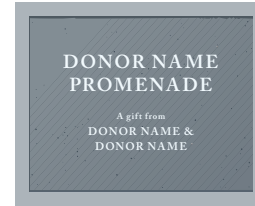
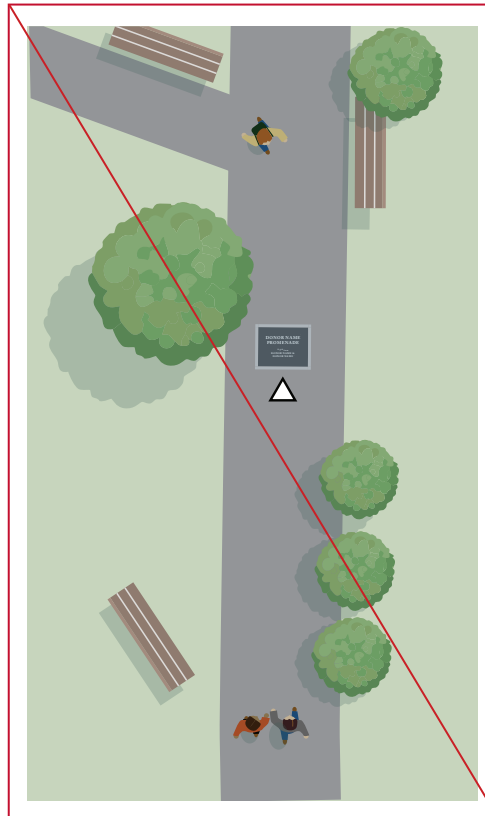

x1

Not to be Approved

A single large size paver in a long pathway appears awkward in placement, and has the downside of only being read in a single direction.

Applications for Courtyard and Centralized Spaces

Exterior Spaces & Promenades | Bluestone Pavers

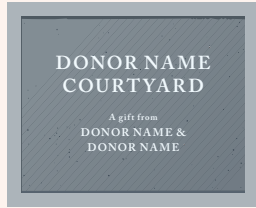
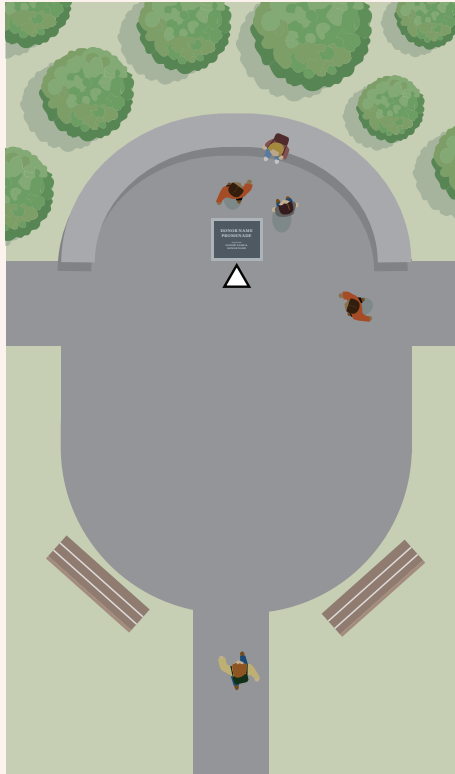

x1

Recommended:

Pavers are the preferred recognition sign type for large exterior courtyards and plazas.

Use a single, large-size paver to make acknowledgement in the center of the area.

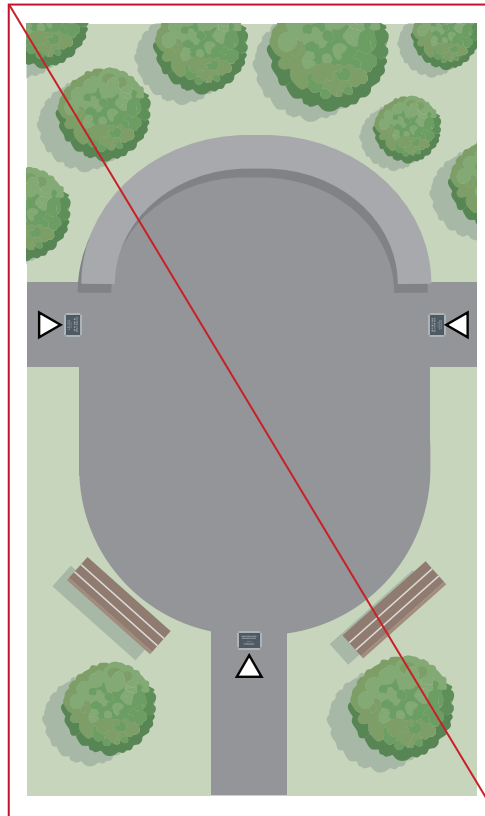

x3

Not to be Approved

Multiple of the same acknowledgment pavers placed in at the entries of centralized spaces creates an unneeded redundancy.

General Specifications

Exterior Spaces & Promenades | Bluestone Pavers

Bluestone Paver

The color specification for pavers on Grounds is known as a "Blue-Blue", "True Blue", "Select Blue", or another brand name. The color is to be a solid light blue with no tonal variations.

The paver is to have a thermally-finished surface to assist footing grip.

The size of the paver depends on the desired scale of the acknowledgement within its space.

The depth of paver depends on the use of its environment, and will be 1.5"-2" for pedestrian; confirm thickness with engineer for vehicular loading. Pavers with larger surface area should be of a thicker depth.

Engraving

Letters are to be sand carved, 3/16" to 1/8" deep, depending on what is deemed optimal for the size of text. A simple dark shadow-colored infill may be appropriate for legibility within the letters.

Embedding Process and Border Incorporation

Pavers and running bond edging brick to be installed on mortar setting bed, neatly incorporated within its surrounding ground environment.

A clean weather-durable seal is essential for the paver's longevity.

Facilities Management's masons, a paving specialist, and the Office of the Architect should be coordinated with to determine the proper conditions and methods for installation.

Alternative Material Considerations

Any material not listed, but desired for its qualities, must be assessed by the Office of the Architect.

Consider cost, maintenance, and accordance with surrounding environmental conditions and architecture.

Proposed material samples should be procured and examined in their desired landscape.



Example Observations

This is much variation of plaques for Featured Spaces on Grounds.

The most suitable references for materiality standards are the plaques which engraved Grayson slate, whereas the most suitable references for layout are the plaques which establish hierarchy between the identification and other text elements.

Best Practices & 2025 Precedent

Exterior Spaces & Promenades | Wall-Mounted Option

Bluestone pavers are the ideal medium of acknowledgement for exterior spaces, with some considerations to depending on site conditions alternatives. Criteria for OAU Approval is as follows:

- 1. Coordination** Present all site, conditions and designs to OAU.
- 2. Content & Typography.** The plaque paver should identify the space is relates to above the recognized donor name. All content to be Adobe Caslon typeface, to layout specifications.
- 3. Materiality and Design** 1'-6" x 8" Grayson Slate plaque, of honed finish, with a 1/2" Hollywood Bevel on its edges is the only acceptable material for Featured Space Plaques. All text is engraved 1/32" - 1/16" deep, and should receive a white satin infill.
- 4. Placement & Mounting** Generally, plaques should be mounted at a height of 48" to 60" on a wall correlated to the area it identifies. Stud mount flush to existing wall with & silicone. Studs are 1/3-20 threaded, and placed 2" on center.

Considerations for Vertical Integration

Exterior Spaces & Promenades | Wall-Mounted Option

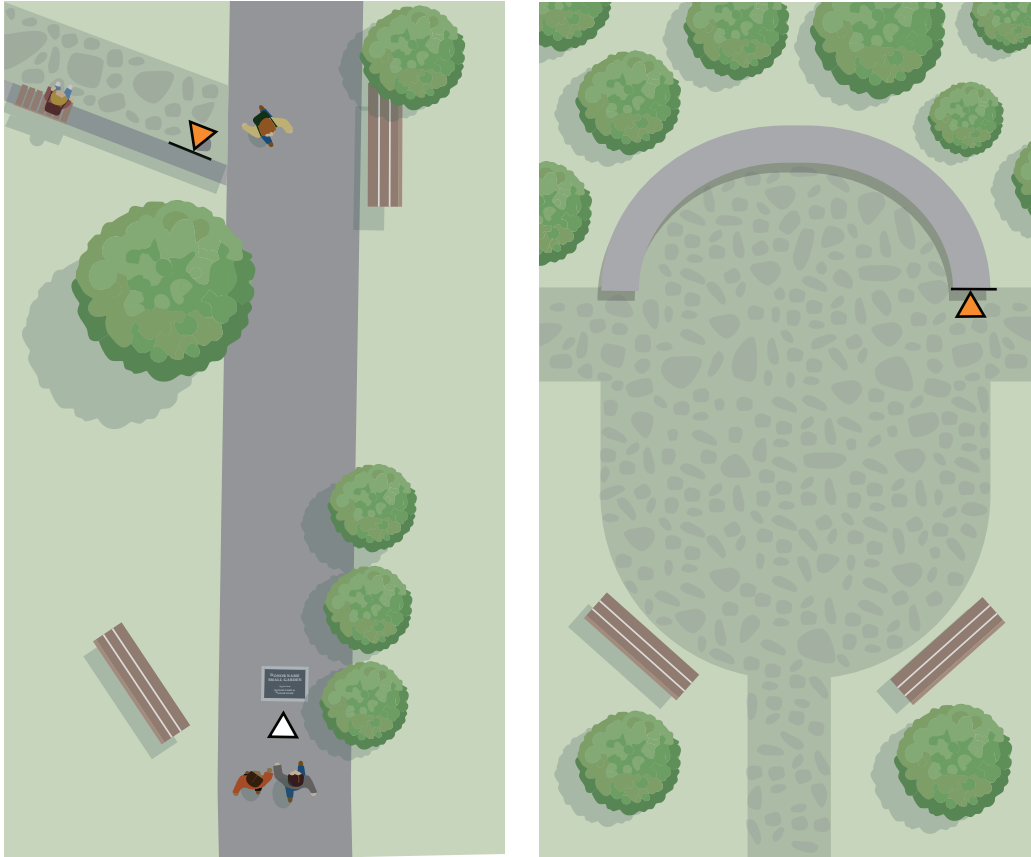

Consideration Conditions like flagstone or concrete paving may not favor the incorporation of a Bluestone Paver at the ideal placement points.

DONOR PROMENADE

A gift from

DONOR NAME &
DONOR NAME

Consider Vertical Integration

A wall-mounted plaque may be appropriate if placed in an approved location.

Ideally, these signs types would be placed on existing walls. If there is a walled entry point to the exterior space, place to the right wall of the entry.

Exterior Feature ID Plaque

Exterior Spaces & Promenades | Wall-Mounted Option



Exterior Feature ID

Only to be used if conditions favor a wall-mounted treatment over the paver options.

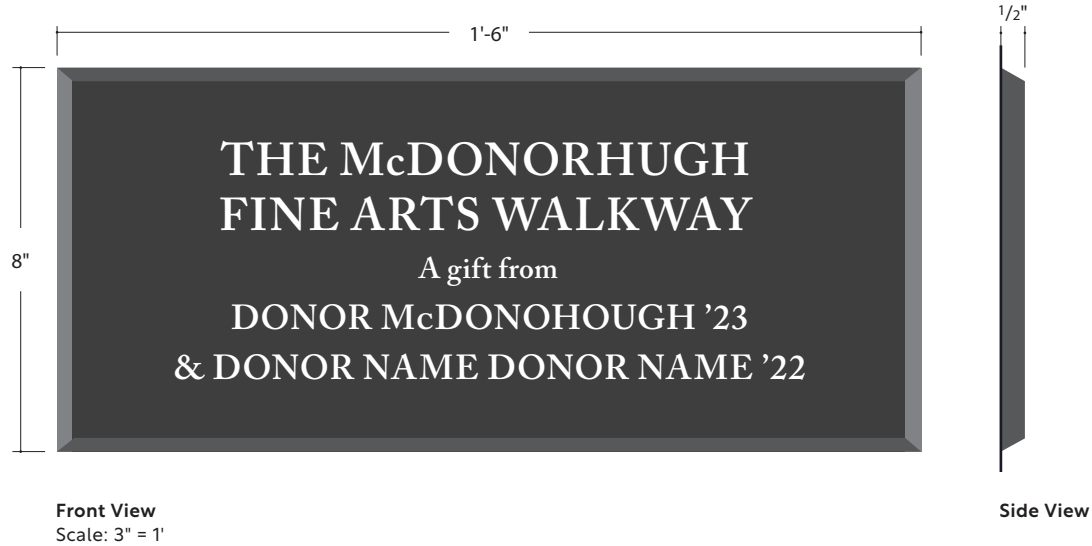

Material: 1/2" thick Grayson Slate of honed finish with a 1/2" Hollywood bevel around the edges of the plaque.

Letter Engraving: Sand carved, 1/32"- 1/16" deep (shallow blast). Engraved text contains an infill of White Satin paint.

Content Overview & Layout Anatomy 1/3

Exterior Spaces & Promenades | Wall-Mounted Option

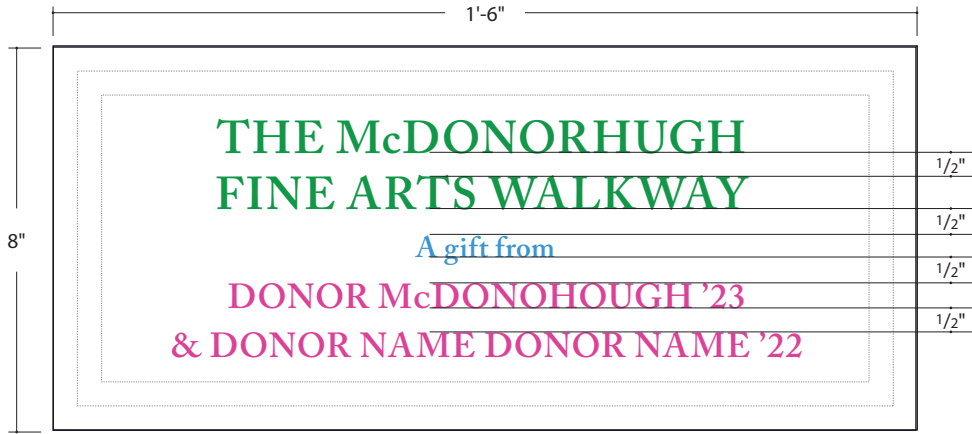

Measurements on diagram mark distance between elements and section blocks

Border Bevel

1/2" around slate edge

Text Margin

1" around slate edge

All Content Centered in Plaque

A text margin of 3/8" around the edges of the plaque ensures an aesthetic fitting of text.

Font: Adobe Caslon Pro, Semibold

Identification: 1/2", 1 to 2 lines, ~44 char.

Uppercase, Center-aligned

Byline: 1/4", ~50 characters

Sentence Case, Center-aligned

Recognition: 3/8", 1 to 2 lines, ~60 char.

Uppercase, Center-aligned

Content Overview & Layout Anatomy 2/3

Exterior Spaces & Promenades | Wall-Mounted Option

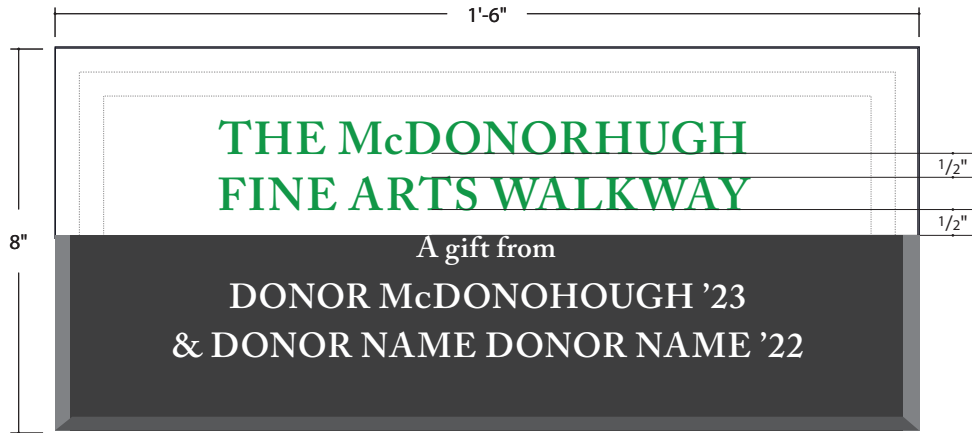

Measurements on diagram mark distance between elements and section blocks

Border Bevel

1/2" around slate edge

Text Margin

1" around slate edge

All Content Centered in Plaque

A text margin of 3/8" around the edges of the plaque ensures an aesthetic fitting of text.

Font: Adobe Caslon Pro, Semibold

Identification: 1/2", 1 to 2 lines, ~44 char.

Uppercase, Center-aligned

Identification uses donor name if acknowledgement is Dedication.

Concise format – dedications do not need full "legal" name here.

No grad years, or schools names to be included here.

Content Overview & Layout Anatomy 3/3

Exterior Spaces & Promenades | Wall-Mounted Option

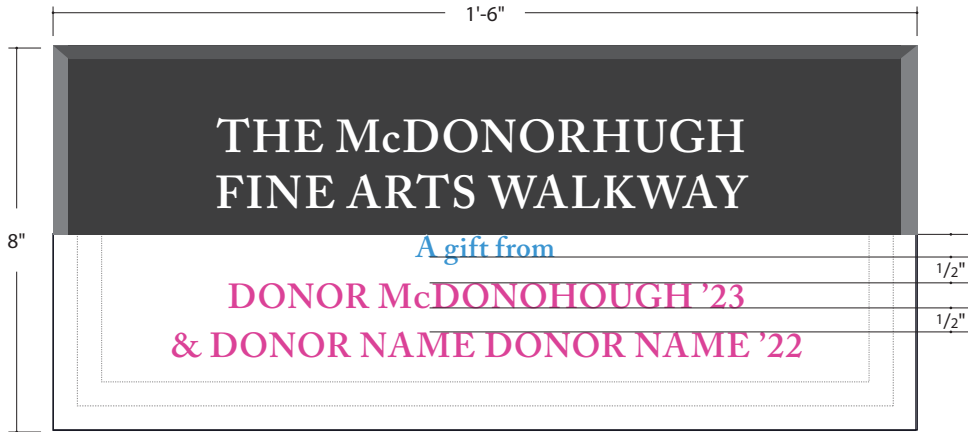

Measurements on diagram mark distance between elements and section blocks

Border Bevel

1/2" around slate edge

Text Margin

1" around slate edge

All Content Centered in Plaque

A text margin of 3/8" around the edges of the plaque ensures an aesthetic fitting of text.

Font: Adobe Caslon Pro, Semibold

Byline: 1/4", ~60 characters

Sentence Case, Center-aligned

Byline alludes to type of acknowledgment.
Standard bylines are:

- "A gift from"
- "In honor of"
- "In memory of"
- "in tribute to"

Recognition: 3/8", 1 to 2 lines, ~42 char.

Uppercase, Center-aligned

Grad year to be abbreviated in two digits.

In married couples, woman's name appears first.

Family names are to be combined to appear in single instance.

Ampersands "&" used when applicable.

No schools names are to be included.

Content Guidance per Acknowledgement Type

Exterior Spaces & Promenades | Wall-Mounted Option

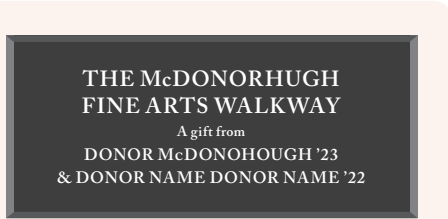

THE McDONORHUGH
FINE ARTS WALKWAY
A gift from
DONOR McDONOUGH '23
& DONOR NAME DONOR NAME '22

Recognition: Byline uses "A GIFT FROM", followed by donor name.

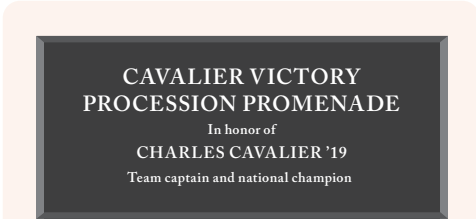

CAVALIER VICTORY
PROCESSION PROMENADE
In honor of
CHARLES CAVALIER '19
Team captain and national champion

Honorific: Byline uses "IN HONOR OF", followed by donor name. It is appropriate for another Byline-format text underneath the honored party for quote or context line.

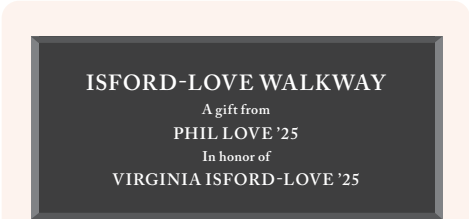

ISFORD-LOVE WALKWAY
A gift from
PHIL LOVE '25
In honor of
VIRGINIA ISFORD-LOVE '25

Tributary: Byline uses "A GIFT FROM", followed by donor name as well as "IN HONOR OF" or "IN MEMORY OF" the tribute party.

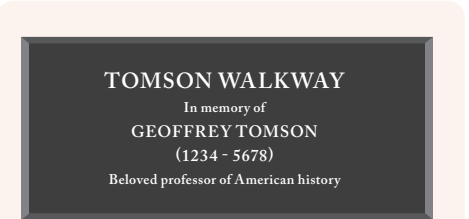

TOMSON WALKWAY
In memory of
GEOFFREY TOMSON
(1234 - 5678)
Beloved professor of American history

Memorial: Byline uses "IN MEMORY OF". It is appropriate for another line of Recognition-format text for years lived and for Byline-format text below that to offer context.

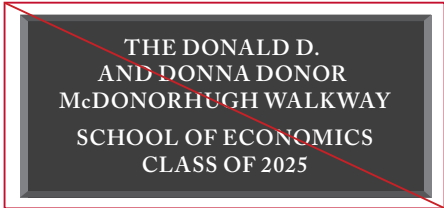

Not to be Approved

The headline should only identify the feature as it is named, and not be used for the acknowledged party's entire name.

Hierarchy between Identification and Recognition sizes are essential to disseminate content. Do not use one size for two types of content.

Placement

Exterior Spaces & Promenades | Wall-Mounted Option

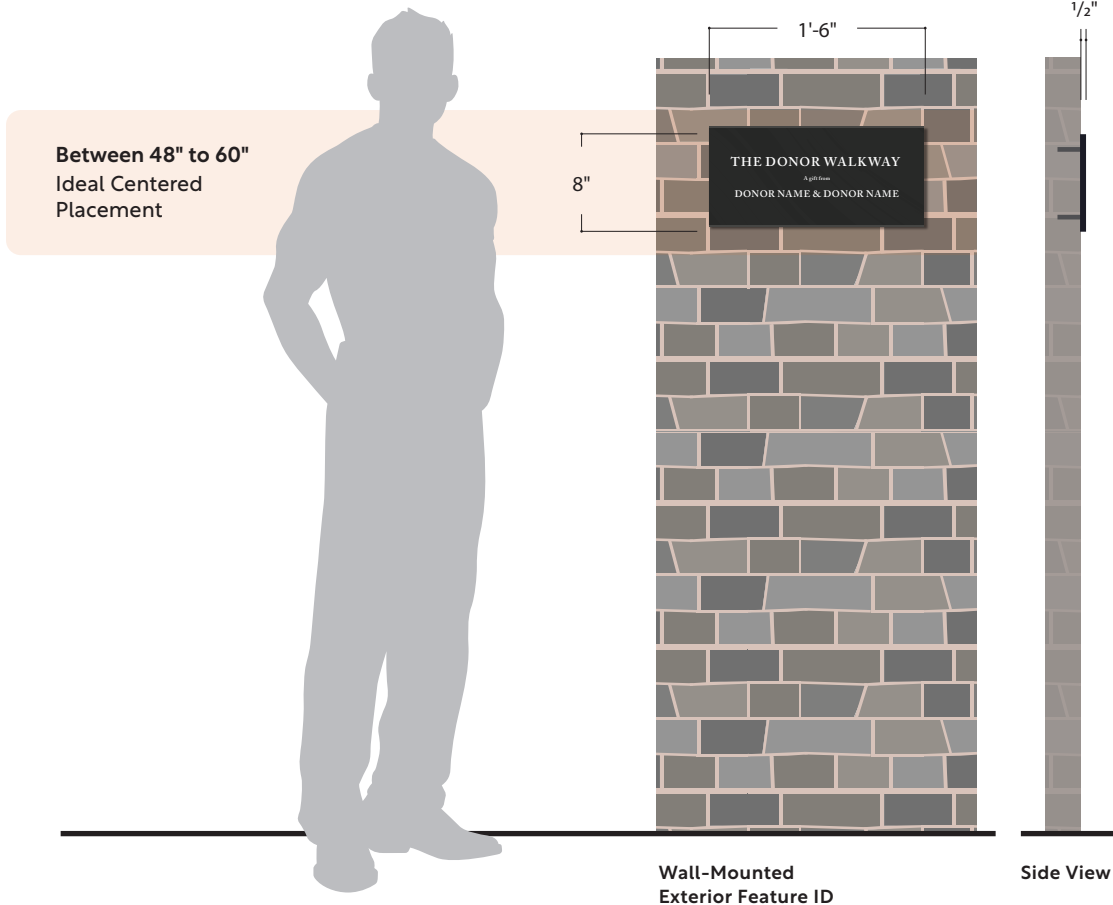

Placement Height is Threshold

A height threshold is given to accommodate for various architectural circumstances. Generally, plaques should be mounted at a height of 48" to 60" on a wall correlated to the area it identifies. If at an entry, the right-hand wall is preferred. The plaque should be placed in a well-lit spot that would not receive debris or water runoff from above.

Mounted and Sealed

Stud mount flush to existing wall with & silicone.
Studs are 1/3-20 threaded, and placed 2" on center.

Feature Identification Plaque Material Notes

Exterior Spaces & Promenades | Wall-Mounted Option

Grayson Slate

This stone, mined from Virginia's Arvonja Quarry, is the standard and traditionally-used material for Building Dedicatory Plaques

The stone is specified as a 1'-6" x 8" x 3/4" or 2 cm thick slab of Grayson slate, cut to size.

Face is to be smooth honed.

Edges are to be have a "Hollywood Bevel" style 1/2".

Letter Copy Decoration

Sand carved, 1/32" - 1/16" deep (shallow blast).

Copy contains an infilled with a White Satin MAP from Matthews Paint Company.

Mounting Mechanism

Blocking to be coordinated / confirmed in desired location prior to placement.

Stud mount flush to existing wall & fill with silicone.

Studs are 1/3-20 threaded, and placed 2" on center.

Material Not Listed

Any material not listed, but desired for its qualities, must be assessed by the Office of the Architect.

Consider cost, maintenance, and accordance with surrounding environmental conditions and architecture.

Proposed material samples should be procured and examined in their desired landscape.

7

Exterior Feature Object

Bluestone Paver Feature ID

Wall-Mounted Exterior Feature ID

Freestanding Feature ID

Overview of Integration Types

Exterior Feature Object ID



Ground Integration

The preferred treatment for a feature located in an open exterior area with available paving space.



Wall-Mounted Integration

The preferred treatment for a feature located in an open exterior area with available, correlating wall space.



Freestanding Integration

The last preferred option, only for features located in a landscape area with no available paving or correlating wall space.

Paver Overview

Exterior Feature Object ID | Ground Integration

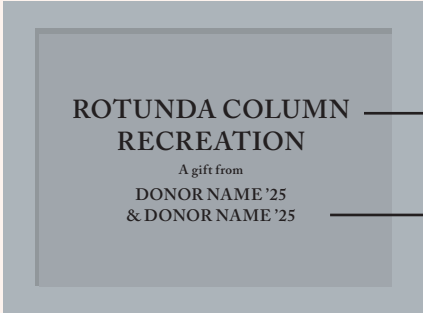

Recommended Identification Text Size

2" letter height

Acknowledgment Text Size

1" letter height

This application follows the same standards as the **Small Bluestone Paver** in considerations to size, layout, and installation requirements.

Wall-Mounted Integration Overview

Exterior Feature Object ID | Wall-Mounted Integration

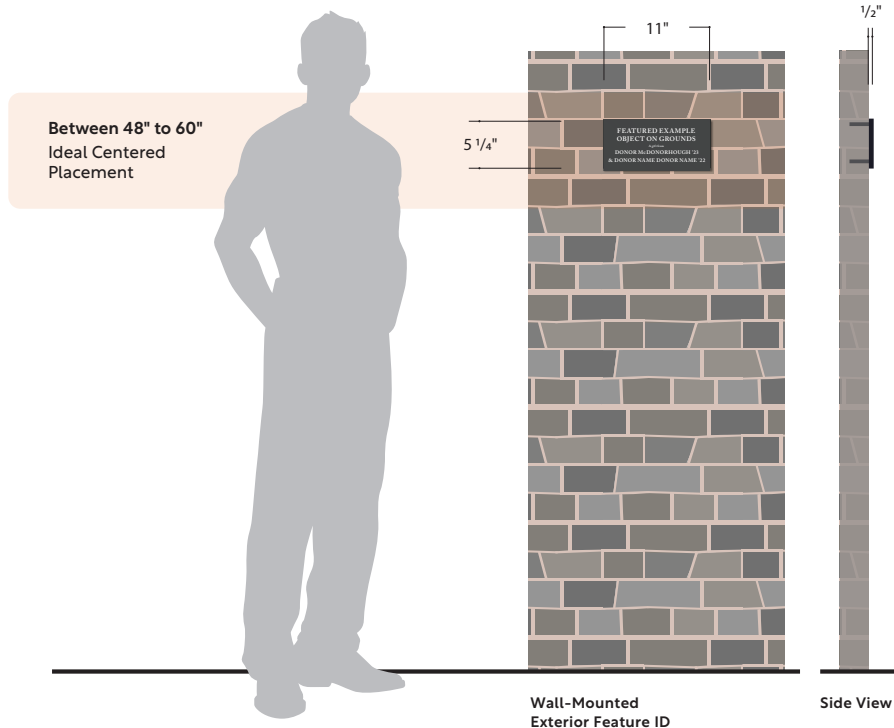

FEATURED EXAMPLE OBJECT ON GROUNDS

A gift from

DONOR McDONORHOUGH '23
& DONOR NAME DONOR NAME '22

Material: 1/2" thick Grayson Slate of honed finish with satin white letters.

Letter Engraving: Sand carved, 1/32"- 1/16" deep (shallow blast). Copy contains an infilled with a White Satin MAP from Matthews Paint Company.

Placement & Mounting: Between 48" to 60" on a wall correlated to the featured object it identifies. Studs are 1/3-20 threaded, 2" on center, and sealed into wall using weather-resistant silicone.

Content Overview and Layout Anatomy 1/3

Exterior Feature Object ID | Wall-Mounted Integration

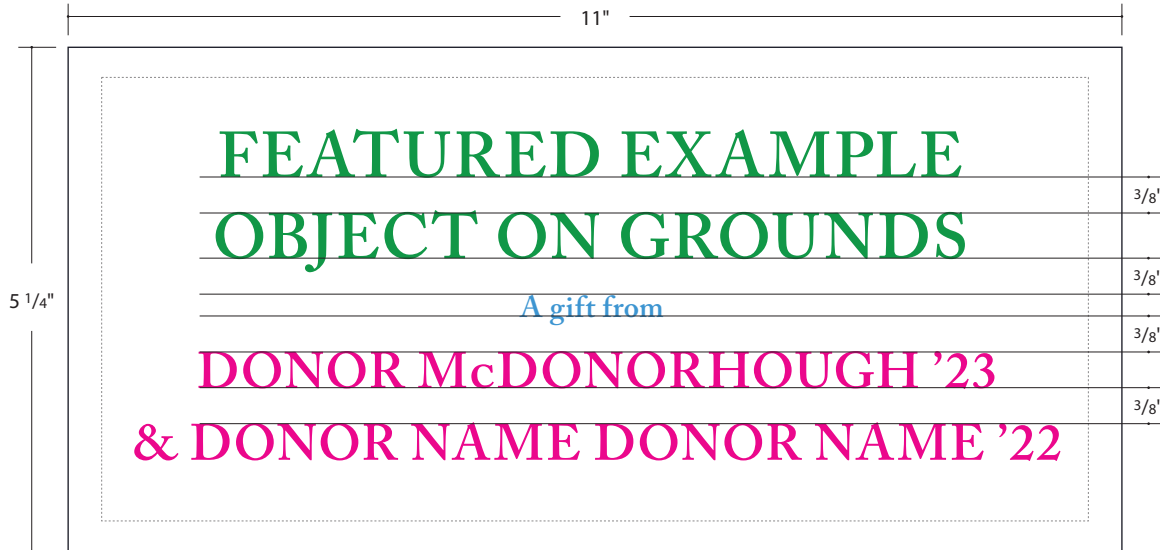

Measurements on diagram marks distance between text elements

Border Bevel

1/2" around slate edge

Text Margin

1" around slate edge

All Content Centered in Plaque

Text margins ensure an aesthetic fitting of text

Font: Adobe Caslon Pro, Semibold

Identification: 1/2", 1 to 2 lines, ~38 char.

Uppercase, Center-aligned

Byline: 1/4", ~60 characters

Sentence Case, Center-aligned

Recognition: 3/8", 1 to 2 lines, ~42 char.

Uppercase, Center-aligned

Content Overview and Layout Anatomy 2/3

Exterior Feature Object ID | Wall-Mounted Integration

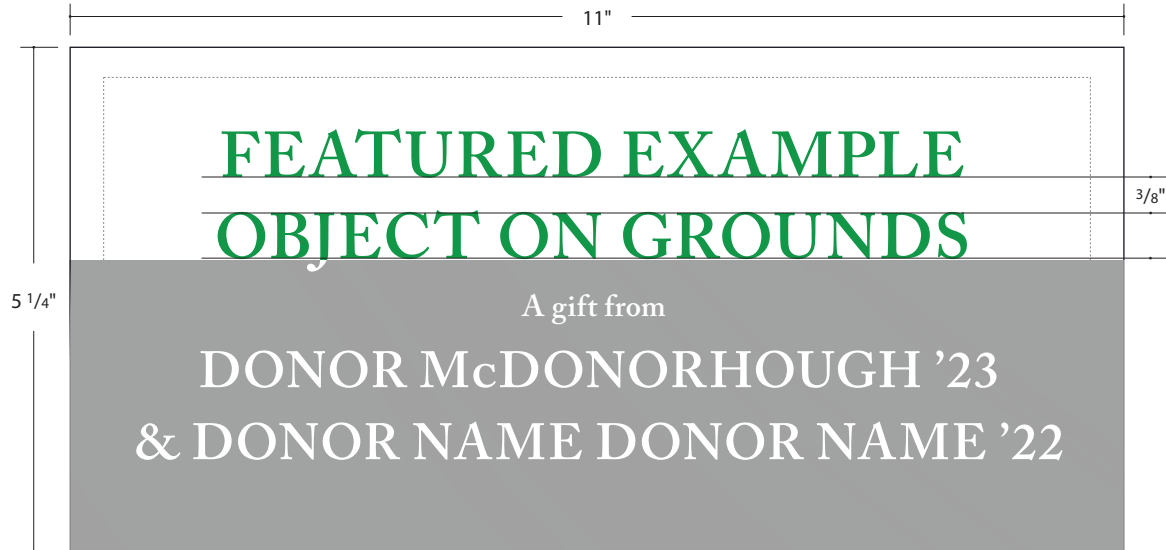

Measurements on diagram marks distance between text elements

Border Bevel

1/2" around slate edge

Text Margin

1" around slate edge

All Content Centered in Plaque

Text margins ensure an aesthetic fitting of text

Font: Adobe Caslon Pro, Semibold

Identification: 1/2", 1 to 2 lines, ~38 char.

Uppercase, Center-aligned

Concise format, dedications do not need full "legal" name here.

No grad years, or schools names are to be included here.

Content Overview and Layout Anatomy 3/3

Exterior Feature Object ID | Wall-Mounted Integration

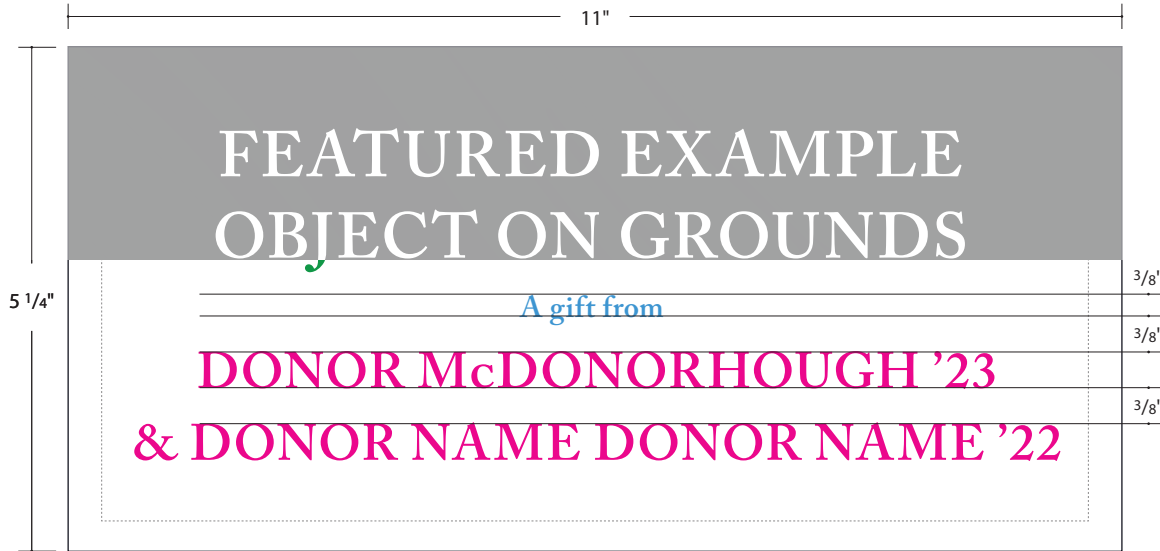

Measurements on diagram marks distance between text elements

Border Bevel
1/2" around slate edge

Text Margin
1" around slate edge

All Content Centered in Plaque
Text margins ensure an aesthetic fitting of text

Font: Adobe Caslon Pro, Semibold

Byline: 1/4", ~60 characters

Sentence Case, Center-aligned

Byline alludes to type of acknowledgment.

Standard bylines are:

- "A gift from"
- "In honor of"
- "In memory of"
- "In tribute to"

Recognition: 3/8", 1 to 2 lines, ~42 char.

Uppercase, Center-aligned

Grad year to be abbreviated in two digits.

In married couples, woman's name appears first.

Family names are to be combined to appear in single instance.

Ampersands "&" used when applicable.

No schools names are to be included.

Content Guidance per Acknowledgement Type

Exterior Feature Object ID | Wall-Mounted Integration

CLASSICAL STATUE RESTORATION

A gift from

DONOR McDONORHOUGH '23
& GINA GENOROUSITY '24

Recognition: Byline uses "A GIFT FROM", followed by donor name.

CHAMPIONSHIP MONUMENT

In honor of

CHARLES CAVALIER JR.
Who rallied our team while riding horseback

Honorific: Byline uses "IN HONOR OF", followed by donor name. It is appropriate for another Byline-format text underneath the honored party for quote or context line.

VISITOR'S ARCHWAY

A gift from

PHIL LOVE '25

In honor of

VIRGINIA ISFORD-LOVE '25

Tributary: Byline uses "A GIFT FROM", followed by donor name as well as "IN HONOR OF" or "IN MEMORY OF" the tribute party.

TOMSON MARKER

In memory of

GEOFFREY TOMSON '23

(1234 - 4567)

Memorial: Byline uses "IN MEMORY OF". It is appropriate for another byline for years lived.

~~CLASSICAL STATUE
RESTORATION
A GIFT FROM
THE McDONORHUGH
FAMILY~~

Not to be Approved

The Identification should only identify the feature as it is named, and not be used for the acknowledged party's name.

Hierarchy using Identification and Acknowledgement sizes are essential to disseminate content. Do not use one size for two types of content.

Freestanding Integration Overview

Exterior Feature Object ID | Free-Standing Integration

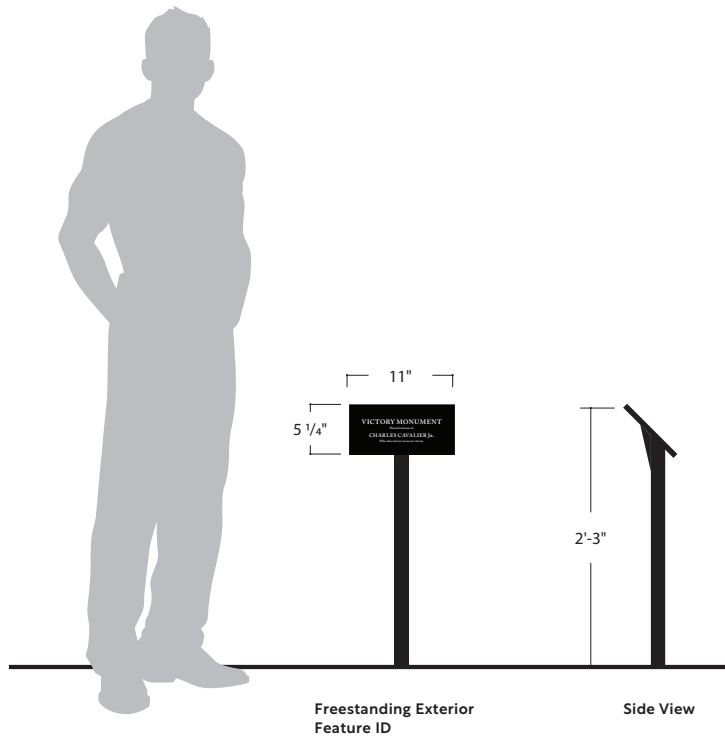

THE GIANT SCULPTURE

A gift from

DONOR NAME & DONOR NAME

This application follows the same standards as the **Feature ID, Wall-Mounted Application** in considerations to content and layout.

Close-Up View

Exterior Feature Object ID | Free-Standing Integration

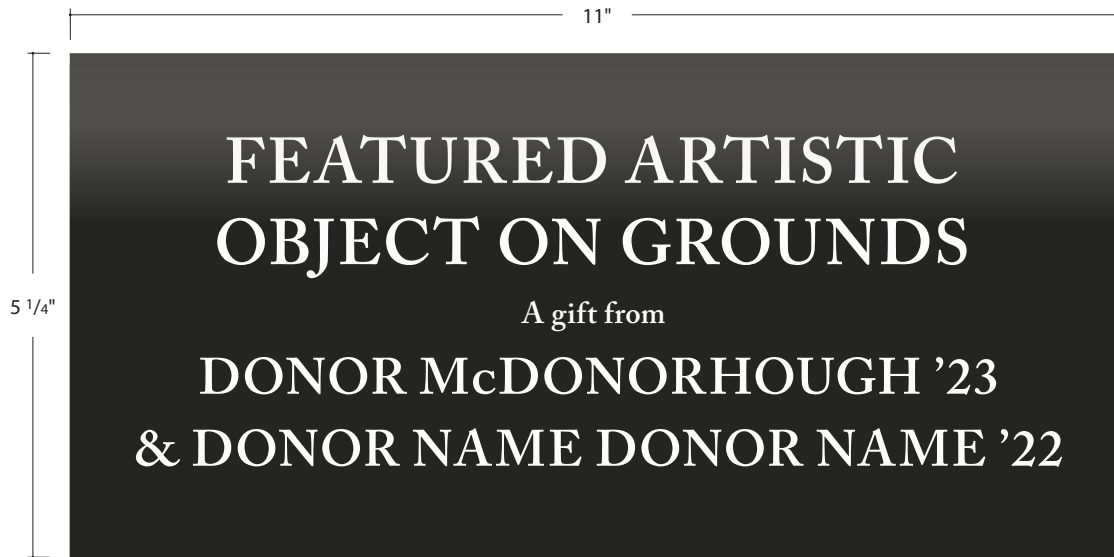

Front View
Scale: 6" = 1'

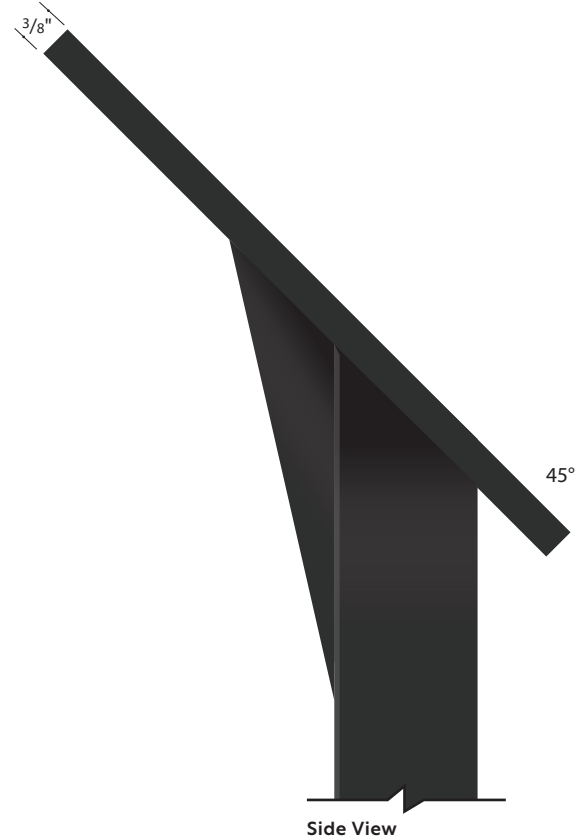

Content Guidance per Acknowledgement Type

Exterior Feature Object ID | Free-Standing Integration

CLASSICAL STATUE RESTORATION

A gift from
DONOR McDONORHOUGH '23
& GINA GENOROUSITY '24

Recognition: Byline uses "A GIFT FROM", followed by donor name.

CHAMPIONSHIP MONUMENT

Placed in honor of
CHARLES CAVALIER JR.
Who rallied our team while riding horseback

Honorific: Byline uses "IN HONOR OF", followed by donor name. It is appropriate for another byline-format text underneath the honored party for quote or context line.

VISITOR'S ARCHWAY

A gift from
PHIL LOVE '25
In honor of
VIRGINIA ISFORD-LOVE '25

Tributary: Byline uses "A GIFT FROM", followed by donor name as well as "IN HONOR OF" or "IN MEMORY OF" the tribute party.

TOMSON MARKER

In memory of
GEOFFREY TOMSON '23
(1234 - 4567)

Memorial: Byline uses "IN MEMORY OF". It is appropriate for another byline for years lived.

~~CLASSICAL STATUE
RESTORATION
A GIFT FROM
THE McDONORHUGH
FAMILY~~

Not to be Approved

The Identification should only identify the feature as it is named, and not be used for the acknowledged party's name.

Hierarchy using Identification and Acknowledgement sizes are essential to disseminate content. Do not use one size for two types of content.

Construction Detail

Exterior Feature Object ID | Free-Standing Integration

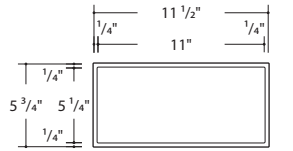

Plan View - Flattened Panel

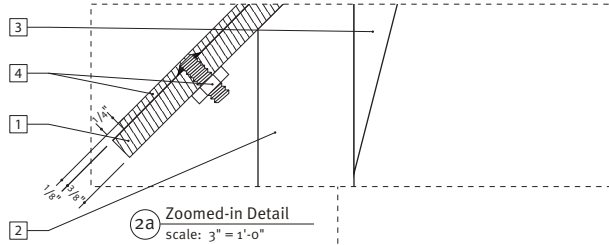

2a Zoomed-in Detail
scale: 3" = 1'-0"

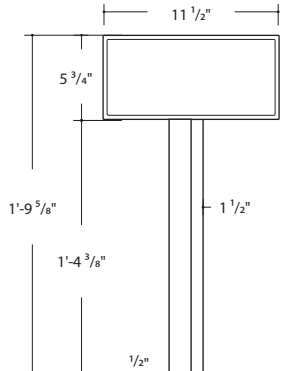

1 Front Elevation
scale: 1 1/2" = 1'-0"

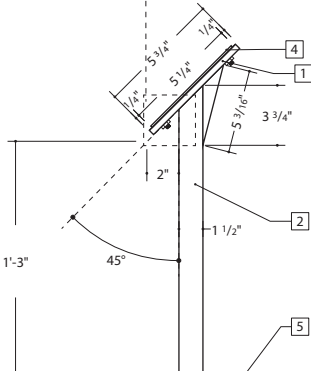

2 Right Side Elevation
scale: 1 1/2" = 1'-0"

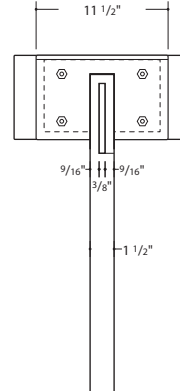

Stand Materiality

Aluminum, painted to spec: Matthews Acrylic Polyurethane Paint, Medium MP833 R229865, PROC BLACK C Textured Black Suede Finish, 287112SP

Plaque Materiality

Dark Anodized aluminum, with text engraved 1/32" - 1/16" and given a white paint infill.

- 1 3/8" thick aluminum, v-groove and fillet weld to 1 1/2" x 1 1/2" aluminum square tube, grind down all welds to be smooth and seamless
- 2 1 1/2" x 1 1/2" aluminum square tube, cut, v-groove and fillet weld to the back of aluminum panel, grind down all welds to be smooth and seamless
- 3 Cut 3/8" aluminum plate support, v-groove and fillet weld to the back of aluminum panel and tube, grind down all welds to be smooth and seamless
- 4 1/8" thick, removable, aluminum panel with threaded stainless steel studs welded to the back, mounted to aluminum backer with tamper resistant nuts and washers
- 5 Aluminum tube to be direct buried into landscaping, verify all existing conditions prior to shop drawings and inform designer of any issues that will affect design intent

8

Interior Feature Space

3 1/2" to 7" Dimensional Letters for Dedications

Interior Space ID Plaque

Sign Type Applications

Interior Feature Space

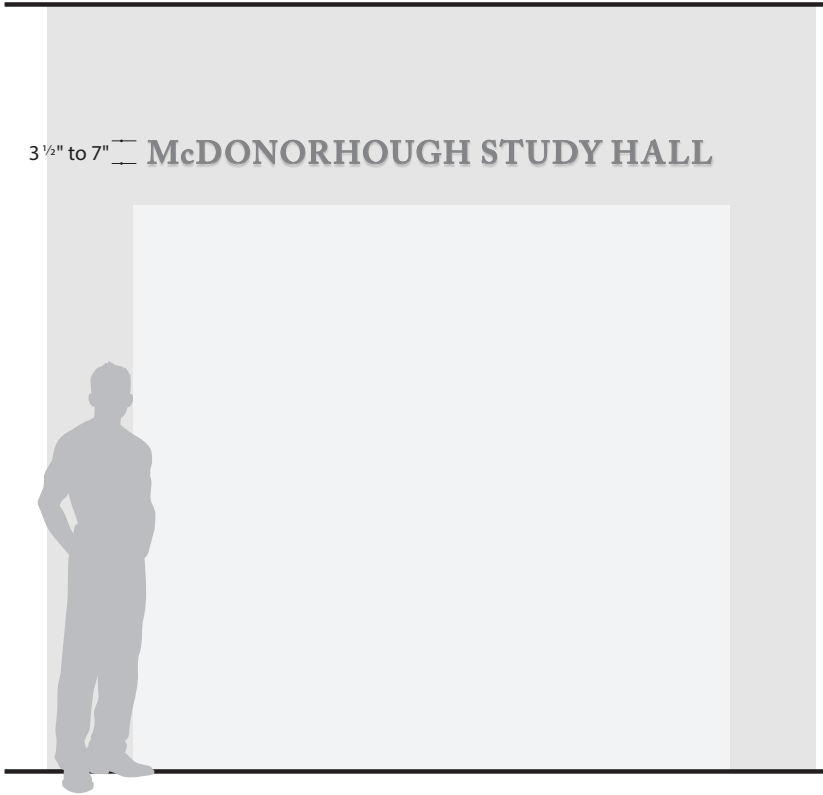

Dimensional Letters for Interior Feature Space ID

Typical / Historic Palette

Scale 3/8" = 1'



Contemporary Palette



Athletic Use

Interior Feature Space Plaque



Typical / Historic Palette

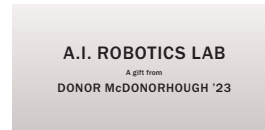

Contemporary Palette



Athletic Palette

Scale 3" = 1'

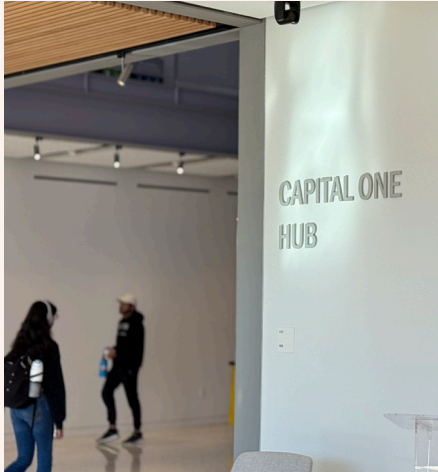

Example Precedent and Observations

Both the Capital One Hub and the William E. Pease Rehearsal Hall are of standards to size, materiality, and placement.

Nomenclature should be concise, but descriptive. The William E. Pease Rehearsal Hall would be just as clear without the middle initial, and the Capital One Hub could have been given a functional name.



Best Practices & 2025 Precedent

Dimensional Letters for Interior Space Dedication

A method of identifying open or large spaces directly onto wall surfaces. (Note that the rules for dimensional letters laid out in this section apply for both dedicated and nondedicated spaces).

- 1. Coordination** Present content, site conditions, and proposal to OAU.
- 2. Nomenclature Content** Concise donor name and minimal functional name. Family names are unified when applicable.
- 3. Typography** Style and use of building determines use of Caslon, Franklin, or Cavalier fonts. Letters are to be set in all Uppercase.
- 4. Design** Letters are 3 1/2" to 7" in height, with no depth greater than 1". The color, material, or effect of the letters achieves a legible contrast against the wall they are placed on.
- 5. Placement and Orientation** 6' off of the ground is the ideal lower baseline, and 1' below ceiling is the maximum height. If placed by a corner or entryway, there should be 6" padding from edges. Letters are to be right-aligned or center-aligned (if over doorway).

Typestyle & Fonts

Interior Feature Space | Dimensional Letters for Dedication

McDONORHOUGH STUDY HALL

McDONORHOUGH RESEARCH HALL

McDONORHOUGH TROPHY HALL

Letters are to be set in all-Uppercase format.

Traditional Palette: Adobe Caslon Pro, Semibold

Appropriate for buildings deemed by the OAU to be of the traditional style of Grounds.

Contemporary Palette: Franklin Gothic URW, Medium

Appropriate for buildings deemed by the OAU to be of the contemporary architectural style of Grounds.

Athletic Use: UVA Cavalier Font, Bold

Appropriate for buildings deemed by the OAU and Athletics Department to be of athletic use on Grounds.

~~STUDY HALL~~

~~STUDY HALL~~

~~Study Hall~~

Not to be Approved

Typefaces, fonts, and typestyles outside of these standards will not be approved. Incorrect uses of approved fonts is not acceptable.

Lowercase and Small-Caps typestyles are not to be used.

Letter Height Size

Interior Feature Space | Dimensional Letters for Dedication

3 1/2" to 7"
McDONORHOUGH
STUDY HALL

Typography Size is a Range

Dimensional letters are to be 3 1/2" to 7" in height.

The range is provided to accommodate donor name size, prominence of recognition in its environment, available wall space, and reading distance.

letters larger than 7"
McDONORHOUGH
STUDY HALL

letters smaller than 5"
McDONORHOUGH
STUDY HALL

Not to be Approved

Sizes of letters outside of the given range, or at a size not legible or appropriate for their reading distance will not be approved.

Letter Materiality & Contrast

Interior Feature Space | Dimensional Letters for Dedication



DONOR NAME
STUDY AREA

70% Contrast and Good Lighting

70% contrast is desired through materiality / color against their wall color. Legibility can be achieved through use of dimension and shadow as well.



DONOR NAME
STUDY AREA

Not to be Approved

Dimensional letters which achieve no legible contrast through materiality, color, dimension, or shadow are not permitted.

Letter Depth & Mounting

Interior Feature Space | Dimensional Letters for Dedication

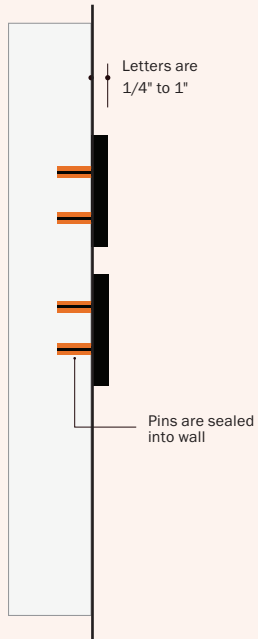

Side view of flush letters

Letter Depth

Dimensional letters are 1/4" to 1" in depth. The preferred face of the letters is flat. One method to decide thickness is to consider 1:8 ratio of width to height.

Letter Mounting

Confirm blocking prior to installation. Ensure that the pins and letters are secure by increasing contact points and using a sealant.

Pin spacers are not a requirement, but may be implemented if there is a desire to create shadows which could help legibility.

Hardware of mounting mechanism to be the same metal as letters to prevent galvanic corrosion. Should multiple metals be detailed, in this regard, they must include a neoprene gasket between them for separation.

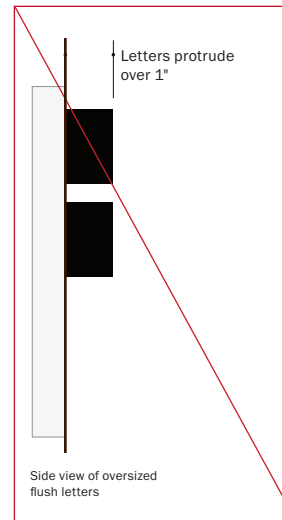

Side view of oversized flush letters

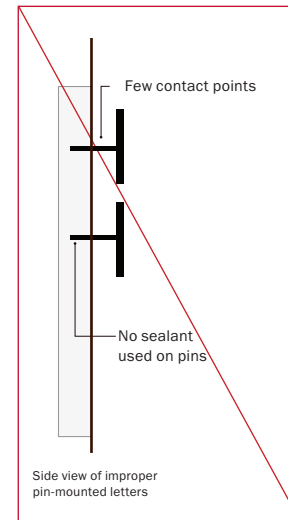

Side view of improper pin-mounted letters

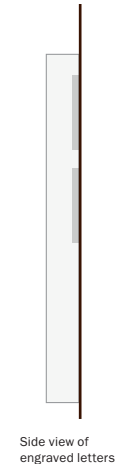

Not to be Approved

Dimensional letters should protrude no more than 1"

Fewer pins equals weak contact points, and risks a higher chance of breaking.

Consult with OAU

Engraved letters are not favored due to their inability to be maintained piece-by-piece. Consult with the Office of the Architect for these options.

Placement

Interior Feature Space | Dimensional Letters for Dedication

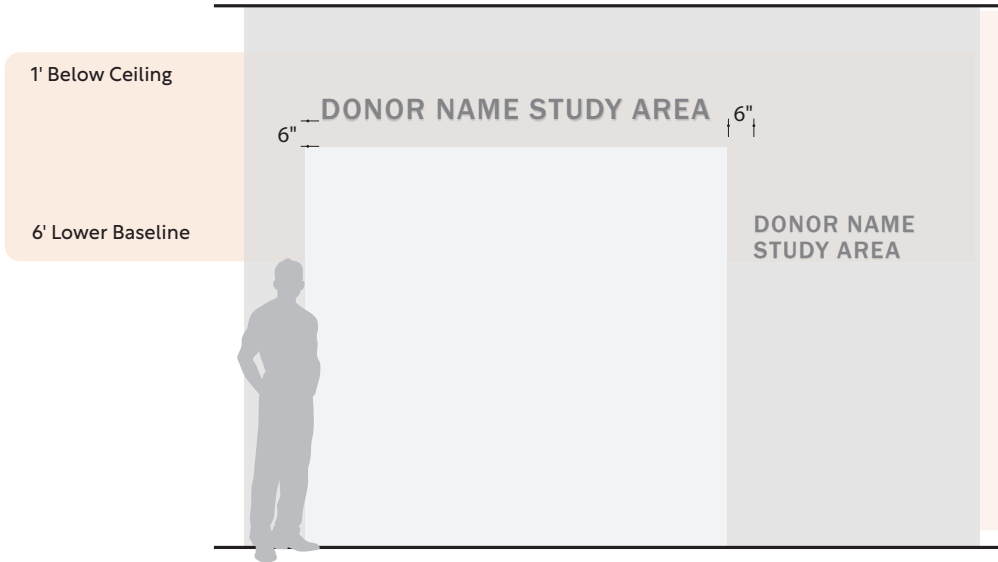

Placement Height is a Threshold

Letters lowest baseline should be at least 6' above floor and 1' below ceiling to prevent tampering and increase legibility.

Letter Size Relates to Placement Height

Letters placed higher in the environment may be of the larger size within the design range to assist legibility, keeping in mind the size of other letters within that vicinity.

Letters Should Relate to Corners and Openings

Generally, a 6" distance creates a clear relationship between the space and its identification.

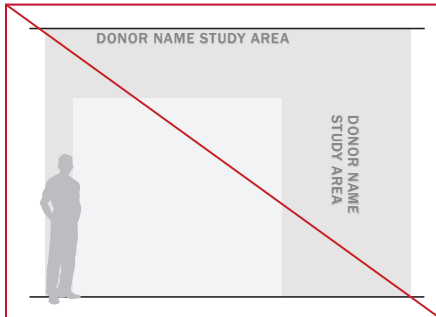

Not to be Approved

Letters should not be placed too high to the ceiling, too low to the ground, or without clear relationship to the dedicated space's entry.

Alignments other than left-to-right reading will not be accepted.

General Specifications

Interior Feature Space | Dimensional Letters for Dedication

Bare / Painted Aluminum

An affordable, readily available option which can provide a high-end polished appearance.

Bare aluminum gives a light silvery gray color, better against darker backgrounds.

Recommended surface treatment is horizontally-brushed with short-grade strokes.

Paint may be matte, satin, or gloss depending on surrounding architectural palette or conditions.

Clear coat offers additional protection against scratches. "ADA Clear" ensures minimal glare.

Anodized Aluminum

This process coats the aluminum letters in a protective and colored preserving the metallic grain finish appearance.

Custom colors are available at an additional expense from the fabricator.

Durable, though the color can still scratch away similar to paint. Unlike paint, however – anodized materials are harder to touch up.

Clear coat offers additional protection against scratches. "ADA Clear" ensures minimal glare.

Acrylic

Available in a multitude of styles and appearances to match the interior architecture.

Beware of placing thin (less than 1/4" thick) acrylic letters in direct sunlight, as the heat may cause them to warp or disfigure off of the wall.

All clear or frosted acrylics should include a backer or be back-painted as to cover hardware and shadows which may obscure legibility.

Alternative Material Considerations

Any material not listed, but desired for its qualities, must be assessed by the Office of the Architect.

Consider cost, maintenance, and accordance with surrounding environmental conditions and architecture.

Proposed material samples should be procured and examined in their desired landscape.



Example Precedent and Observations

This example provides no identification of the feature it references, leading the viewer to wonder what the donor's name is attributed to.



The Dayton South Steps is a chosen example because it contains the identification of the featured space with its donor name. The layout of this and design of this sign is not to standards.

Best Practices & 2025 Precedent

Interior Space ID Plaque for Interior Space Dedication

A method of identifying interior spaces that match the building's interior architectural palette.

- 1. Coordination** Present content, site conditions, and proposals to OAU.
- 2. Content** The plaque should identify the space it relates to above the recognized donor name. All content is of layout standards.
- 3. Design & Materiality** Plaques are 11" in width, 5 1/4" in height, and 3/8" in depth. Typography is engraved 1/32" to 1/16" with specified paint to infill the letters. The aluminum finish, and typography of the plaque is dependant on the interior architectural palette of the building they will be placed within.
- 4. Placement Orientation** Wall-mounted, between within the threshold of 48" and 60" high. It is appropriate for these plaques to live at the same height (5') as any room identification plaques within its area.

Designs per Interior Palette

Interior Feature Space | Interior Space ID Plaque

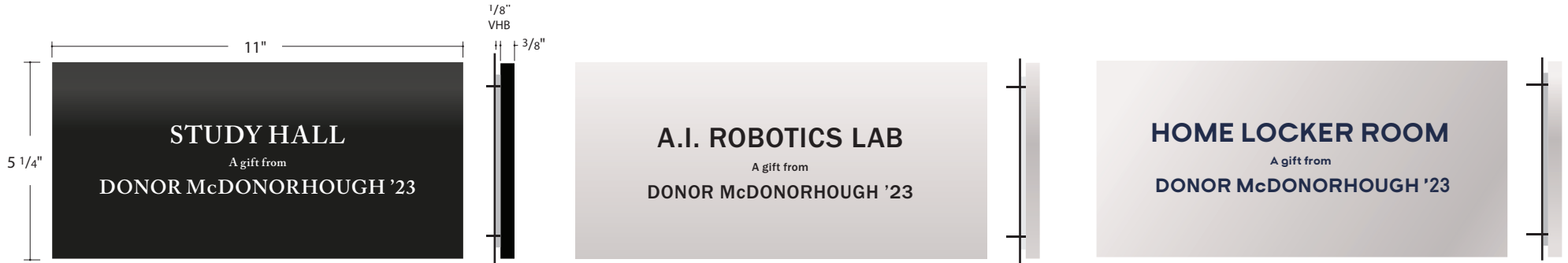

Traditional / Historic Interior Palettes

Horizontally-brushed, short grain, dark anodized 3/8" thick aluminum panel.

Font is in Adobe Caslon Pro, Semibold.

1/32" to 1/16" engraved letters receive a white infill.

Contemporary Interior Palette

Horizontally-brushed, short grain, 3/8" thick aluminum panel.

Font is in Franklin Gothic URW, Medium.

1/32" to 1/16" engraved letters receive a black infill.

Use in Athletic Facilities

Horizontally-brushed, short grain 3/8" thick aluminum panel.

Font is in UVA Cavalier, Bold

1/32" to 1/16" engraved letters receive a UVA Blue infill.

Mounting Mechanism

All plaques are mounted using both pins welded to the back of the frame, and 1/8" 3M VHB Tape inset 1/4" from sides of the plaque.

Content Overview and Layout Anatomy 1/3

Interior Feature Space | Interior Space ID Plaque

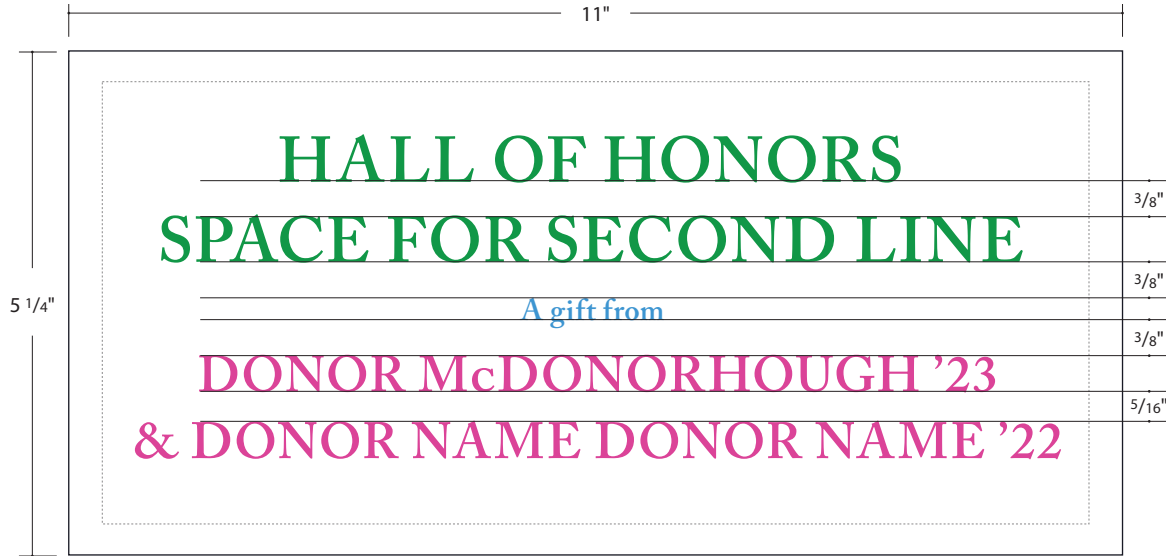

Measurements on diagram mark the distance between text elements.

scale: 6" = 1'

Font per Interior Palette

Typical / Historic: Adobe Caslon Pro, Semibold

Contemporary: Franklin Gothic URW, Medium

Athletic Use: Virginia Cavalier, Bold

All Content Centered in Plaque

A text margin of 3/8" around the edges of the plaque ensures an aesthetic fitting of text.

Identification: 1/2", 1-2 lines, ~38 char.

Uppercase, Center-aligned

Byline: 1/4", ~77 characters

Sentence Case, Center-aligned

Recognition: 3/8", 1-2 lines, ~50 char.

Uppercase, Center-aligned

Content Overview and Layout Anatomy 2/3

Interior Feature Space | Interior Space ID Plaque

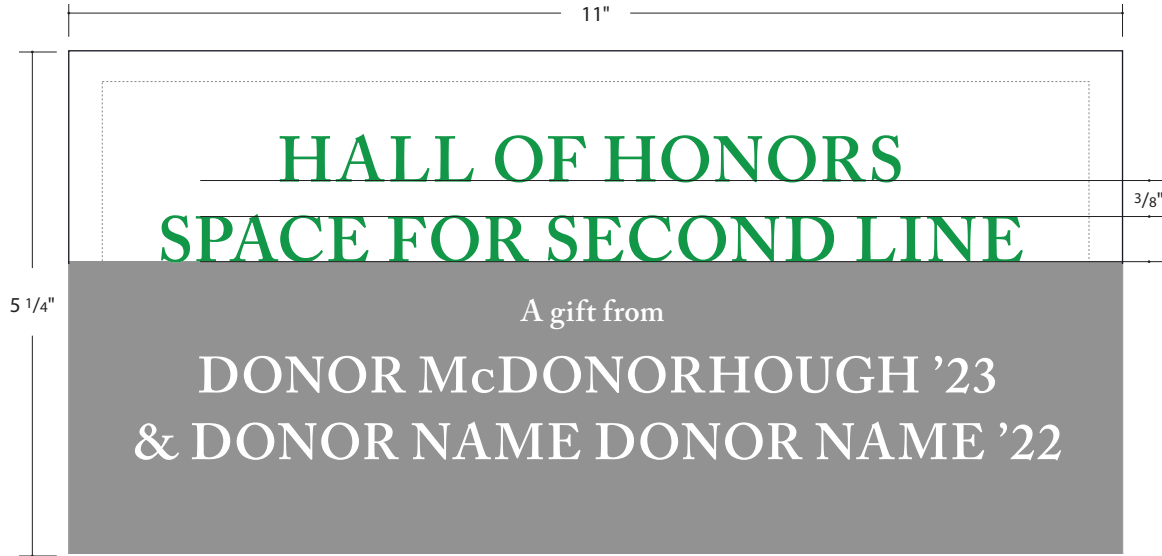

Measurements on diagram mark the distance between text elements.

scale: 6" = 1'

Font per Interior Palette

Typical / Historic: Adobe Caslon Pro, Semibold

Contemporary: Franklin Gothic URW, Medium

Athletic Use: Virginia Cavalier, Bold

All Content Centered in Plaque

A text margin of 3/8" around the edges of the plaque ensures an aesthetic fitting of text.

Identification: 1/2", 1-2 lines, ~38 char.

Uppercase, Center-aligned

Identification uses donor name if acknowledgement is Dedication.

Concise format – dedications do not need full "legal" name here.

No grad years, or schools names to be included here.

Content Overview and Layout Anatomy 3/3

Interior Feature Space | Interior Space ID Plaque

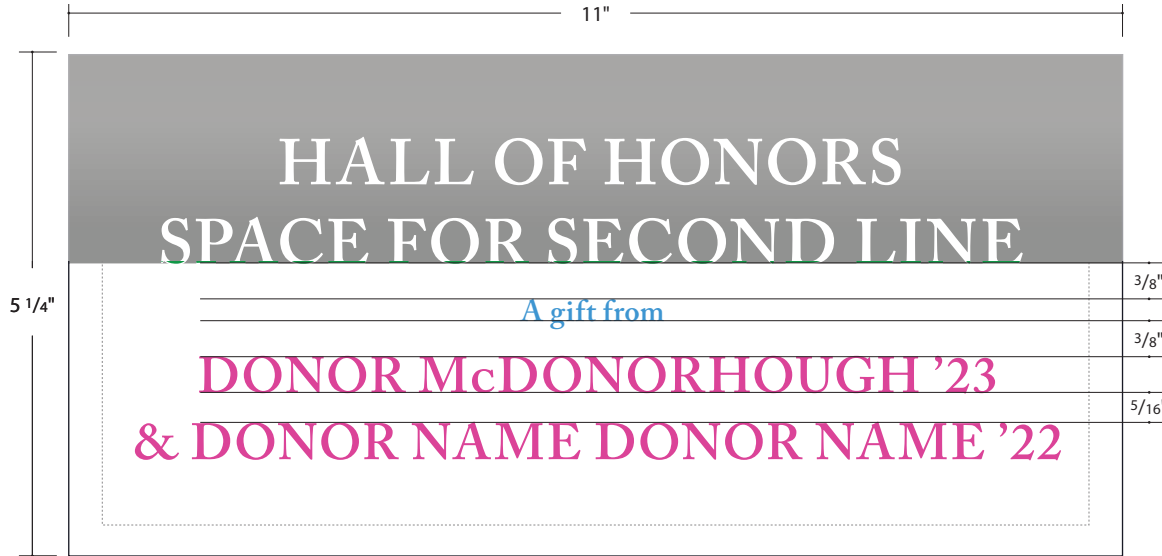

Measurements on diagram mark the distance between text elements.

scale: 6" = 1"

Font per Interior Palette

Typical / Historic: Adobe Caslon Pro, Semibold

Contemporary: Franklin Gothic URW, Medium

Athletic Use: Virginia Cavalier, Bold

All Content Centered in Plaque

A text margin of 3/8" around the edges of the plaque ensures an aesthetic fitting of text.

Byline: 1/4", ~60 characters

Sentence Case, Center-aligned

Byline alludes to type of acknowledgment.

Standard bylines are:

- "A gift from"
- "In honor of"
- "In memory of"
- "In tribute to"

Recognition: 3/8", 1 to 2 lines, ~42 char.

Uppercase, Center-aligned

Grad year to be abbreviated in two digits.

In married couples, woman's name appears first.

Family names are to be combined to appear in single instance.

Ampersands "&" used when applicable.

No schools names are to be included.

Content Guidance per Acknowledgement Type

Interior Feature Space | Interior Space ID Plaque

HALL OF HONORS

A gift from

THE McDONORHOUGH
FAMILY

Recognition: Byline uses "A GIFT FROM", followed by donor name.

BANQUET HALL

In honor of

WORLDY CHEF
Who brought new flavor to the plates of Virginia

Honorific: Byline uses "IN HONOR OF", followed by donor name. It is appropriate for another byline-format text underneath the honored party for quote or context line.

QUIET SEATING

A gift from

PHIL LOVE '25
In honor of
VIRGINIA ISFORD-LOVE '25

Tributary: Byline uses "A GIFT FROM", followed by donor name as well as "IN HONOR OF" or "IN MEMORY OF" the tribute party.

COLLECTION OF COLONIAL GOODS

In memory of

GEOFFREY TOMSON
(1234 – 4567)
Beloved Professor of American History

Memorial: Byline uses "IN MEMORY OF". It is appropriate for another byline for years lived and quote or context line.

~~THE McDONORHOUGH
HALL OF HONORS
A GIFT FROM DONALD
D. DONOR AND DONNA
DONORHOUGH '23~~

Not to be Approved

The Identification should only identify the feature as it is named, and it is not to be used for the acknowledged party's name.

Hierarchy using Identification and Acknowledgement sizes are essential to disseminate content. Do not use one size for two types of content.

Placement

Interior Feature Space | Interior Space ID Plaque

Between 48" to 60"
Ideal Centered
Placement

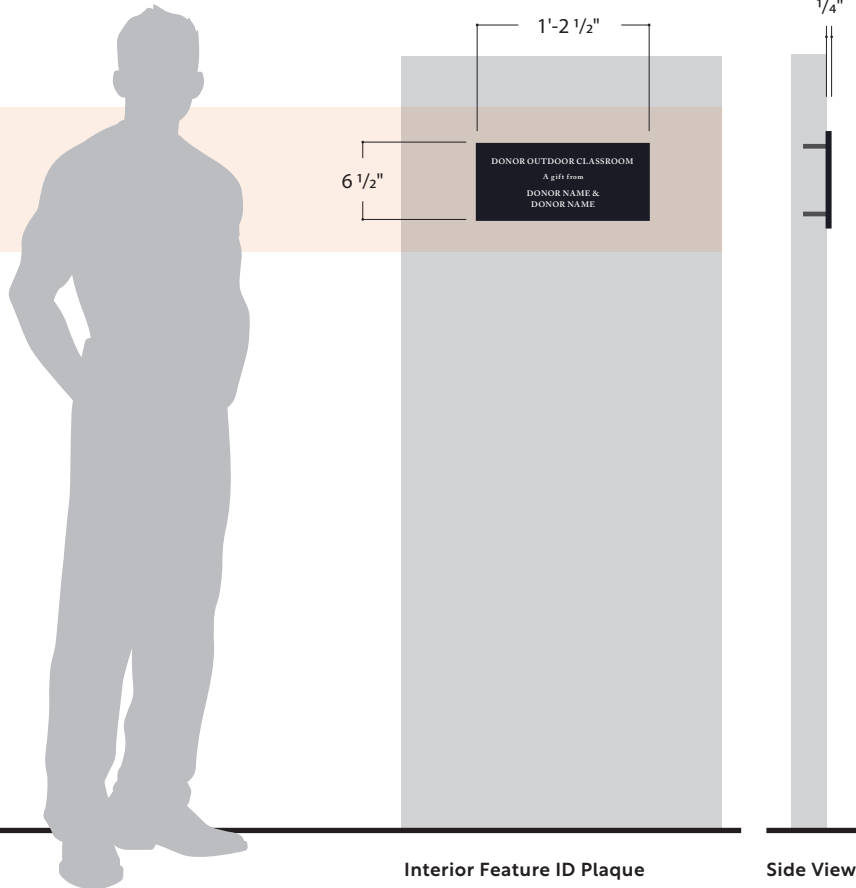

Interior Feature ID Plaque

Side View

Placement Height is a Threshold

Wall-mounted, between the threshold of 48" and 60" high. It is appropriate that these plaques would live at the same baseline as any room identification plaques within its area.

6" Corner Consideration

6" spacing from corners and door edges, preferably on the right-hand side of the entrance, creates a solid relationship between the plaque and the space it acknowledges.

9

Interior Room Recognitions

Room Recognition Plaques

Recognition Plaques with ID

Adapted Use for Interior Features



Example Observations

Classroom 225, with its recognition plaque underneath it, creates the association between the room and the donor names. Kaitlyn's Outdoor Classroom (which is technically tied to the interior palette of the Campbell Hall) is an example of a dedicated "room" that does not require a Tactile ID sign. In these cases, an identification must be included.

Best Practices & 2025 Precedent

Acknowledgement Plaques for Interior Rooms

Placed within the area they correlate to, these plaque identify the space's name and acknowledgment.

- 1. Coordination** Present all site, conditions and designs to OAU.
- 2. Recognition Content** The plaque should include a Sentence-Case byline and identify the donor's name in an all Uppercase format. Additional bylines may be used per recognition type, in order to add context or identify the associated parties within the acknowledgement
- 3. Materiality & Design** Typography is engraved 1/32" to 1/16" with specified paint to infill the letters. The aluminum finish and typography of the plaque is dependant on the interior architectural palette of the building they will be placed within.
- 4. Placement** The plaque should be placed an 5/8" underneath the tactile ID they respond to, or if alone – at the same height as other Tactile Room IDs in the area.

Design per Interior Palette

Interior Unit Recognitions | Room Recognition Plaque

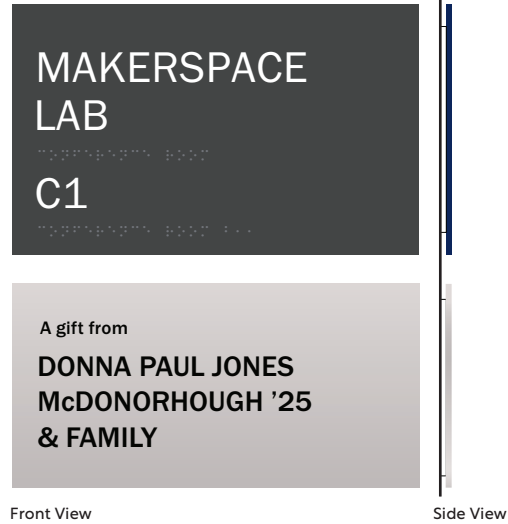

Typical / Historic Palette

Plaque is a horizontally-brushed dark anodized aluminum. Font is Adobe Caslon Pro Semibold, engraved letters have a satin white paint infill.

Contemporary Palette

Plaque is a horizontally-brushed natural aluminum. Type family is Franklin Gothic URW, letters are infilled with satin black paint.

Athletic Palette

Plaque is a horizontally-brushed natural aluminum. Font is Virginia Cavalier, Bold, and letters are infilled with UVA Blue paint.

Content Overview and Layout 1/3

Interior Unit Recognitions | Room Recognition Plaque

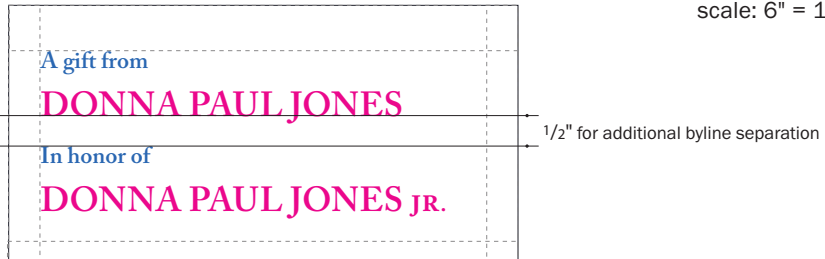

Measurements on diagram mark the distance between text elements.

Font per Interior Palette

Typical / Historic: Adobe Caslon Pro, Semibold

Contemporary: Franklin Gothic URW, Medium

Athletic Use: Virginia Cavalier, Bold

Bottom Text Margin

3/8" from top of plaque

Side Text Margins

1/2" from sides of plaque

Top Text Margin

3/8" from top of plaque

Byline(s): 1/4" ~ 70 Characters

Sentence Case, Right-aligned

Recognition: 7/16", 1 to 3 lines, , ~15 char. per line

Uppercase, Right-aligned

Content Overview and Layout 2/3

Interior Unit Recognitions | Room Recognition Plaque

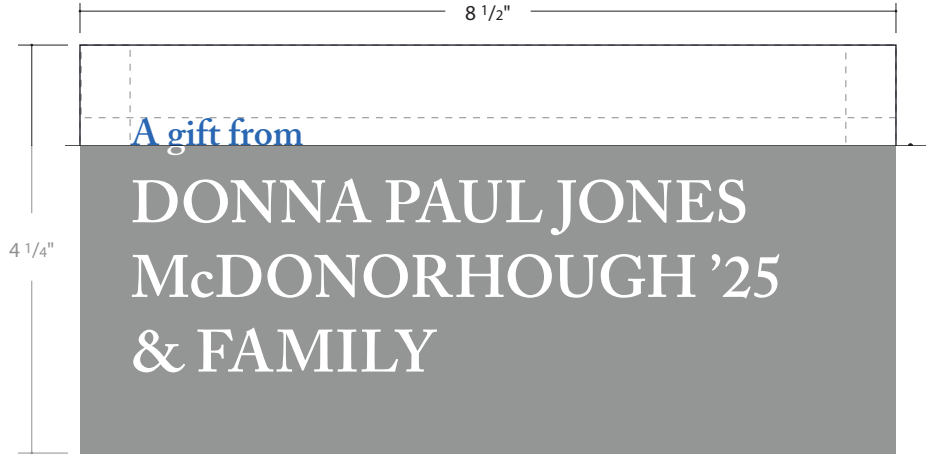

Font per Interior Palette

Typical / Historic: Adobe Caslon Pro, Semibold

Contemporary: Franklin Gothic URW, Medium

Athletic Use: Virginia Cavalier, Bold

Bottom Text Margin

3/8" from top of plaque

Side Text Margins

1/2" from sides of plaque

Top Text Margin

3/8" from top of plaque

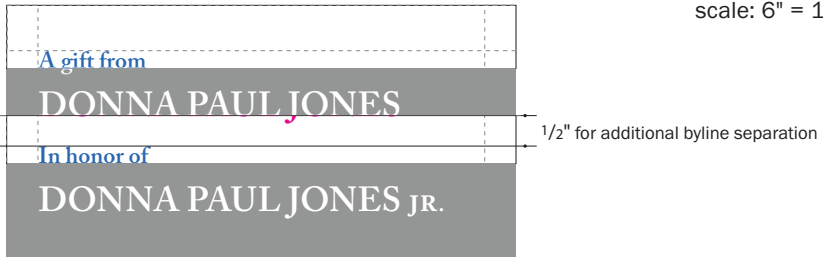

Byline(s): 1/4" ~ 70 characters

Sentence Case, Right-aligned

Byline alludes to type of acknowledgment.

Standard bylines are:

"A gift from"

"In honor of"

"In memory of"

Measurements on diagram mark the distance between text elements.

Content Overview and Layout 3/3

Interior Unit Recognitions | Room Recognition Plaque

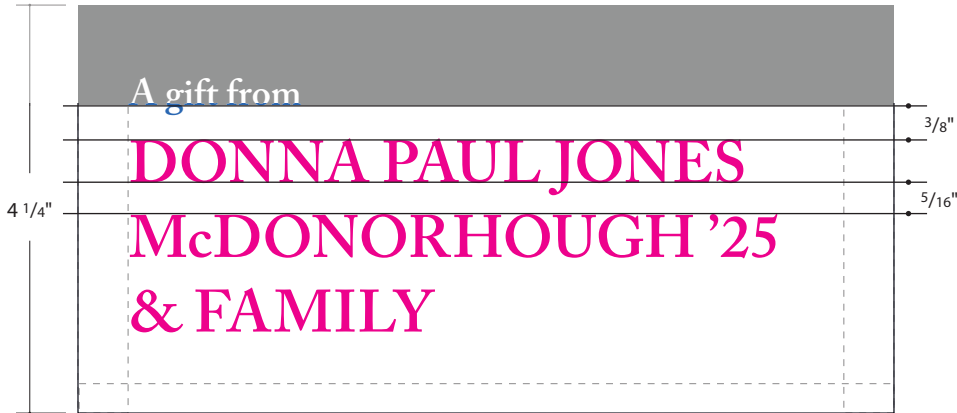

scale: 6" = 1'

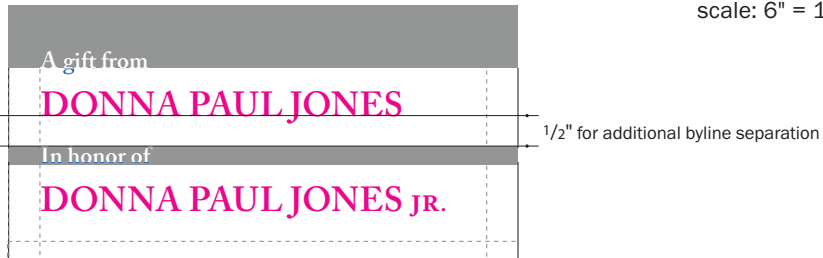

Measurements on diagram mark the distance between text elements.

Font per Interior Palette

Typical / Historic: Adobe Caslon Pro, Semibold

Contemporary: Franklin Gothic URW, Medium

Athletic Use: Virginia Cavalier, Bold

Bottom Text Margin

3/8" from top of plaque

Side Text Margins

1/2" from sides of plaque

Top Text Margin

3/8" from top of plaque

Recognition: 7/16", 1 to 3 lines, ~15 char. per line

Uppercase, Right-aligned

Plaque space is very much limited in order to match the standards of the room ID sign. Acknowledgements need to be as concise as possible, especially in Tributary and Memorial layouts.

Grad year to be abbreviated in two digits.

In married couples, woman's name appears first.

Family names are to be combined to appear in single instance.

Ampersands "&" used when applicable.

No schools names are to be included.

Content Guidance per Acknowledgement Type

Interior Unit Recognitions | Room Recognition Plaque

A gift from
**GINA '24 & DONOR '25
McDONORHOUGH**

Recognition: Byline uses "A GIFT FROM", followed by donor name.

In honor of
**THE CAVALIER
FAMILY**
The pioneers of sports management

Honorific: Byline uses "IN HONOR OF", followed by donor name. It is appropriate for another byline-format text underneath the honored party for quote or context line.

A gift from
PHIL LOVE
In honor of
VIRGINIA ISFORD

Tributary: Byline uses "A GIFT FROM", followed by donor name as well as "IN HONOR OF" or "IN MEMORY OF" the tribute party.

In memory of
GEOFFREY TOMSON
(1234 - 5678)
Beloved professor of American history

Memorial: Byline uses "IN MEMORY OF". It is appropriate for another byline for years lived and quote or context line.

**ROOM GENEROUSLY
GIVEN BY DONALD M.
McDONORHOUGH**
CLASS OF 2025
SCHOOL OF ECONOMICS

Not to be Approved

The Identification should only identify the feature as it is named, and it is not be used for the acknowledged party's name.

Hierarchy using Identification and Acknowledgement sizes are essential to disseminate content. Do not use one size for two types of content.

Design per Interior Palette

Interior Unit Recognitions | Room Recognition Plaque

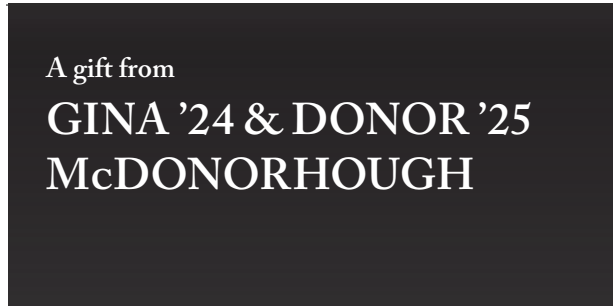

Placement Responds to Tactile Room ID

Room Recognition Signs are to be placed 5/8" underneath the Tactile Room ID sign of which they relate to.

These plaques use the same 1/8" 3M VHB Tape thickness as the Room ID does for mounting, but with the added support of pins welded to the back of the plaque to hold the weight of aluminum.

If the plaque lives on its own for identification purposes, they should be placed at the same height (generally 5') as any other Tactile Room IDs in the area.

Considerations for Identification 1/2

Interior Unit Recognition | Recognition Plaque with Identification



PARTITIONED STUDY POCKETS

A gift from DON McDONORHOUGH '25

In honor of DEBBIE DEDICATED '25



If there is no Tactile Room ID

A space tied to a building's interior can count as a room, but may not require a tactile sign.

Such may be the case for some non-enclosed "room"s and rooms with changing functions.

Adjust Layout for Identification

The Room Recognition Plaque may be adjusted for identification purposes only if there is no accompanying tactile room ID sign.

The layout will be reversed, and must include an identification. Acknowledgements are made in Byline-text format, with names being in Uppercase.

Considerations for Identification 2/2

Interior Unit Recognition | Recognition Plaque with Identification



3" to 6"

JAMES EDWARD RYAN

by Portrait Painter Name, 2025

Oil on Canvas

A gift from ARTHUR PATRON '26

Adjust Layout for Identification

The Room Recognition Plaque may be adapted for identification purposes. The layout will be reversed, with Acknowledgements made in Byline-text format, and with names being in Uppercase.

3" to 6" from Artwork

Plaque should be aligned to a corner of the associated piece, or centered directly underneath the piece.

10

Collective Campaign Guidance

Donor Walls for Renewing Campaigns

Mass Recognition Plaque

Paver Collectives

General Content Rules

Collective Campaign Guidance

Amperstands to be used over "and".

Do not state dollar amounts in acknowledgements.

Avoid using middle names as well as middle initials.

Use alphabetical order when applicable for listing multiple names on collective acknowledgements / donor walls.

This provides a system for which donors can locate their name.

The woman's name appears first in married pairs.

This rule is superseded if only one of the two is a graduate, in which case, the graduate's name will appear first.

Use one family name at the end of multiple donors who share a last name in one instance.

Ex: John, Jim, & Jess Doe

Year of graduation are not included on donor walls or mass recognition plaques. For any paver collections, for alumni appears as '00.

The reason being that the intro section to donor walls / mass recognition plaque should state that the contributions come from alumni, and that these features should list the current year date.

Do not state attended schools or programs in physical recognitions.

It is likely that subject of donors' studies can be inferred by how and where the gift is placed.

Anonymous appear as a singular acknowledgment within collective acknowledgement / donor walls.

Memorials and honorifics appear separate from others in collective acknowledgement / donor walls.

Consult the Office of the Architect for further direction and guidance.

Tiering Standards

Collective Campaign Guidance

Observation: Some campaigns display gift amounts as tier designations, and others have names, or both.

Honor Pledge	Founder's Challenge	Architecture 2023	University 200
Oculus (\$50,000+)	Dome	\$3,000,000	Founders
Dome (\$25,000 to \$49,999)	Colonnade	\$1,000,000	Palladian
Colonnade: (\$10,000 to \$24,999)	Serpentine	\$500,000	Dome
Serpentine: (\$5,000 to \$9,999)	Pavilion	\$250,000	Portico
		\$100,000	
Donors not displayed: Pavilion: (\$2,500 to \$4,999)	* = renewed commitment		

Tiering Option 1: Uniformity
Four tier level names are chosen by the Office of the Architect and would be used for all donor walls on Grounds.

Tiering Option 2: Campaign-Unique
Four tier level names for are chosen by the development office or school where the donor wall will be housed. The tier level names homage the mission of the campaign, helping to market it. The Office of the Architect would still give final approval on the tier level names.

Tiering Option 3: No Tier Level Names
While there would still be four tiers, they are not explicitly shown on giving campaigns and their associated donor walls. To denote tiers, letter size and order of donor names is used adequately.

Recommended: 4 Tiers with no giving amount listed. Hierarchy of gifts are made using scale. The dollar amount associated with each tier should be set on a campaign to campaign basis.

Tier One

1x"

Tier Two

3/4x"

Tier Three

1/2x"

Tier Four

1/4x"

Pieces of a Module System

Collective Campaign Guidance | Donor Walls for Ongoing Campaigns

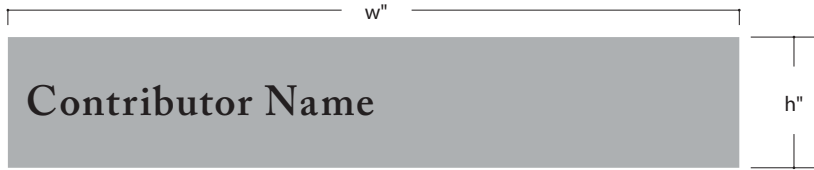

Tier One

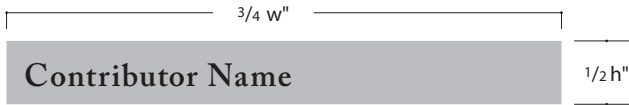

Tier Two

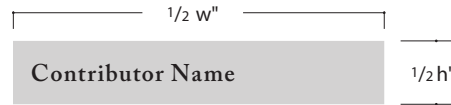

Tier Three

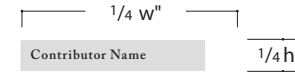

Tier Four

Modular Approach to Yearly Campaigns:
 Create a single wall installation for Yearly Giving Campaigns where donor names are relative to each other for sizing of tiers.

 This installation remains on the wall in a single place.
 Only the modules with names on them need to be updated.

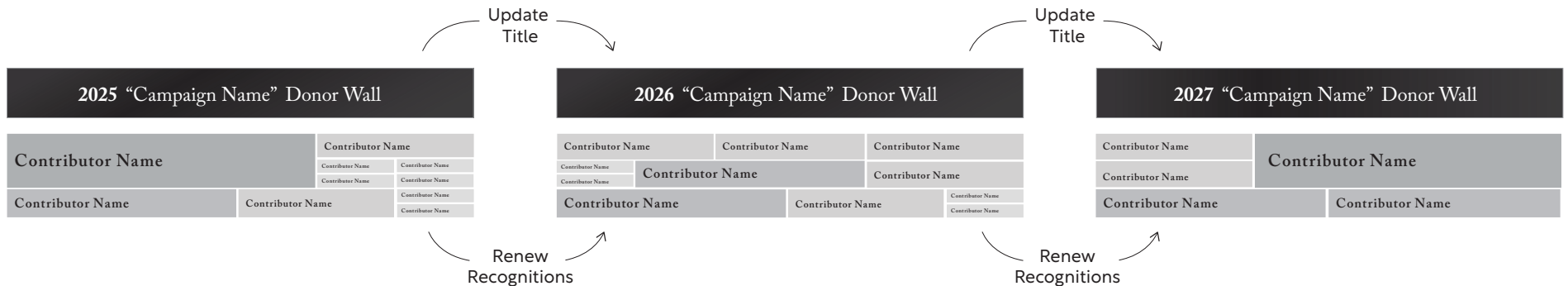

Mass Recognition Plaque Overview

Collective Campaign Guidance | Mass Recognition Plaque



Use Case for Plaque

This type of plaque should only be implemented for collective campaigns that are finite to the completion of a building or similar structure.

They are not appropriate for yearly giving campaigns, or other ongoing campaigns.

Design References Dedicatory Plaques

This sign type should reference the dedicatory plaques in order to keep design standards consistent, as they may exist within the same area.

Layout & Name Tying

Collective Campaign Guidance | Mass Recognition Plaque

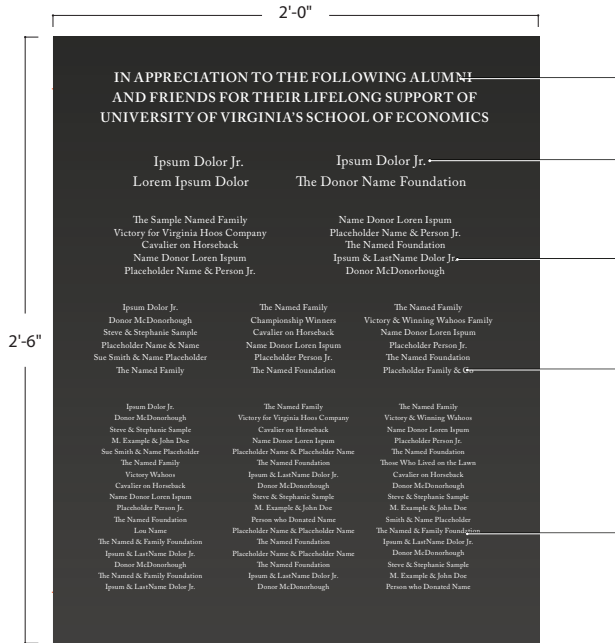

Title: 1/2" letter height, 1 to 3 lines

Tier 1: 1/2" letter height MAX

Tier 2: ~3/8" letter height

Tier 3: ~5/16" letter height

Tier 4: 1/4" letter height MIN

Typography & Sizing

Title appears in all Uppercase.
Donor names are in Sentence-Case.

Assign recognitions to four giving tiers. Size of donor name will respond to the tier of which they are in. Tier 1 being the largest, Tier 4 being the smallest in size. Exact font sizes are dependant on the amount of recognitions and in relation to other recognitions in the area.

Bespoke Layout Per Content

Each Mass Recognition plaque will have a unique amount of donors, so there will be variation in donor name size to accommodate all names. If all names cannot fit onto the plaque, even at low font size, it is then permissible to increase the height size of the plaque.

Design per Interior Palette

Collective Campaign Guidance | Mass Recognition Plaque

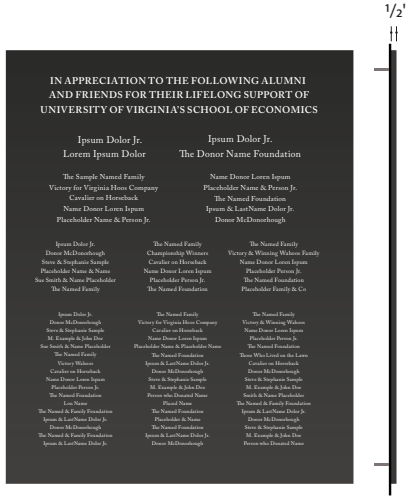

Traditional / Historic Interior Palettes

Horizontally-brushed, short grain, dark anodized 1/2" thick aluminum panel.

Font is in Adobe Caslon Pro, Semibold.

1/32" to 1/16" engraved letters receive a white infill.

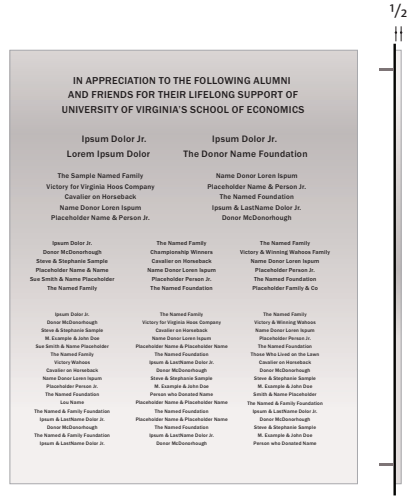

Contemporary Interior Palette

Horizontally-brushed, short grain, 1/2" thick aluminum panel.

Font is in Franklin Gothic URW, Medium.

1/32" to 1/16" engraved letters receive a black infill.



Use in Athletic Facilities

Horizontally-brushed, short grain 1/2" thick aluminum panel.

Font is in Virginia Cavalier, Bold 1/32" to 1/16" engraved letters receive a UVA Blue infill.

Pin Mounting Pins are to be welded to the back of the plaque, sealed in place during its installation.

Creating Paver Hierarchy

Collective Campaign Guidance | Paver Collectives

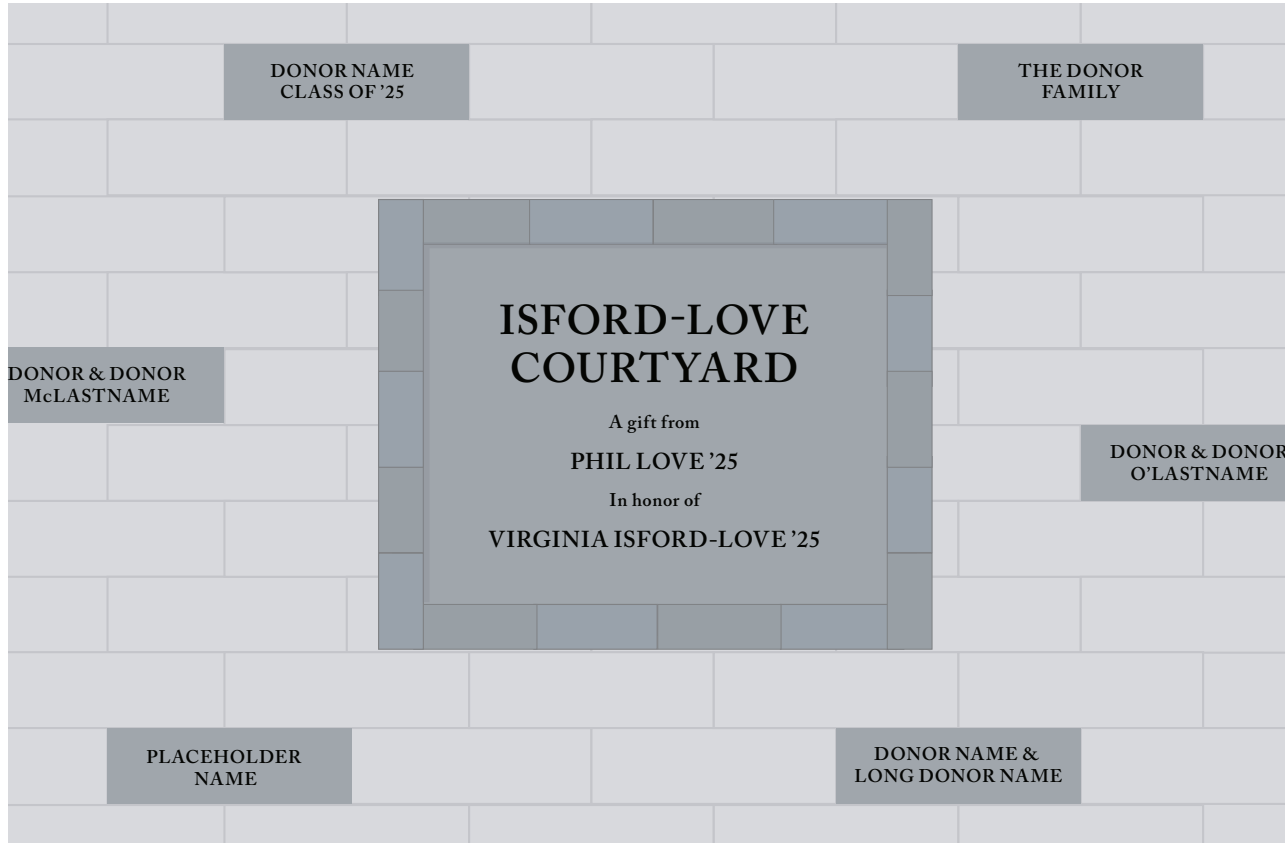

Reference Exterior Spaces & Promenades

An exterior space may have a central dedication which follows the layout structure of the Bluestone Pavers featured in the **Exterior Spaces & Promenades** section.

Paving elements should be incorporated using the materials and paver measurements of the area. This applies to name-only pavers as well. Bluestone is preferred, although brick pavers are acceptable.

Create Hierarchy in Pavers

For collective acknowledgements to the space's dedication, it is appropriate to include 2 lines of available space for the donor's name and abbreviated class year.

Collective acknowledgements are to be no larger than those who are featured on the dedication paver. The byline of the dedication paver makes for a good size reference, size reference, and no engraving shall be smaller than a 1/4".

End of Document

Thank you for your review

[Click here to go back to the Table of Contents](#)